



FORMWORK & SCAFFOLDING

**PRODUCT
CATALOGUE**





CONTENT

ACCESS SCAFFOLDING

SELFLOCK SYSTEM

WALL SYSTEM

COLUMN BOXES

SLAB SYSTEM

PROPS





**ACCESS
SCAFFOLDING**

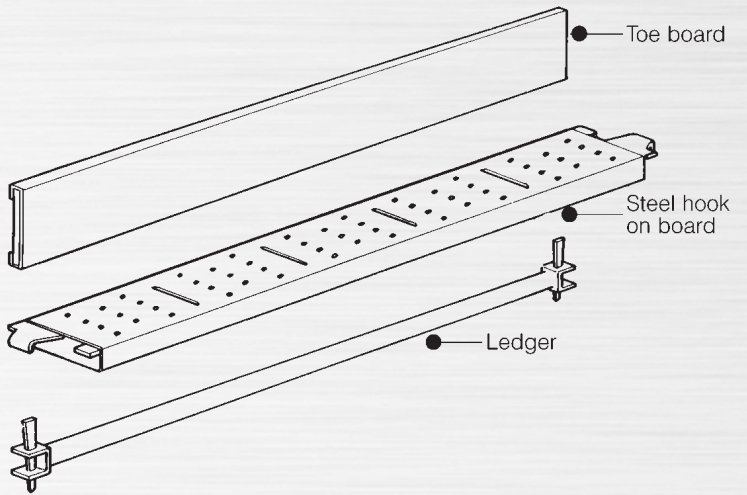
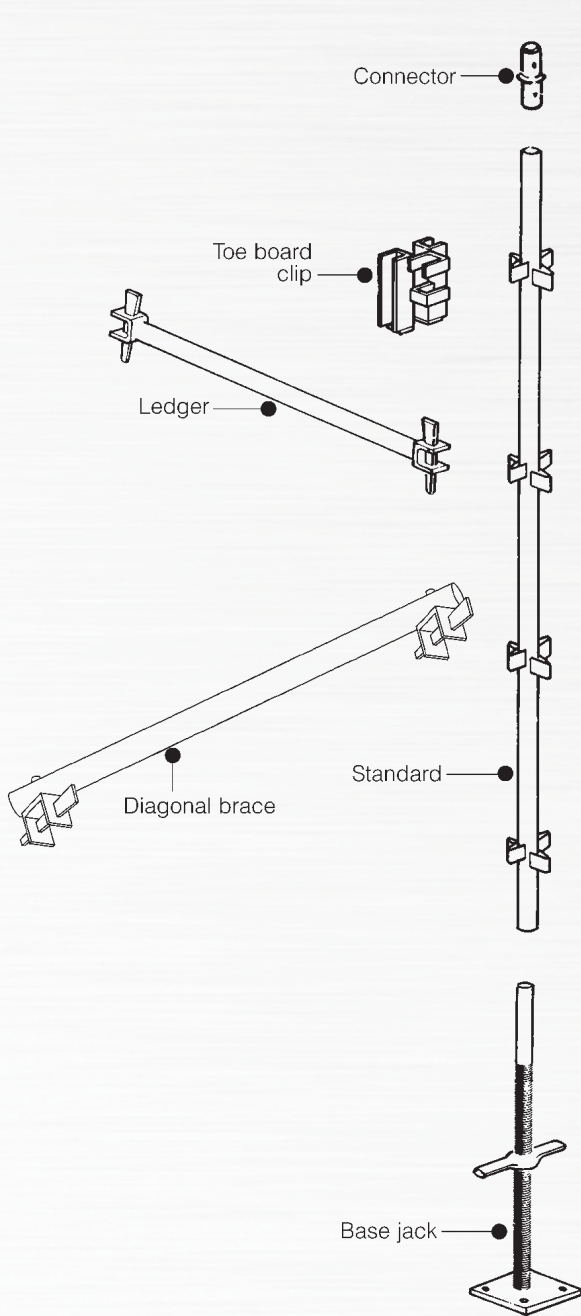

BASE JACK

The base jack is used to adjust height and to level the scaffold.

STANDARD

Standards are manufactured from 48.3 x 3.35 HT scaffolding tube. Clusters of four staggered V-Pressings at 90° to each other are situated at 500mm centres along the length of the standard.

LEDGER

The ledger is manufactured from 48,3 x 2,65 HT scaffolding tube with captive wedge C-Pressings on each end, which locate on the V-Pressings on the standard. The ledgers are normally placed at 2 000mm centres but additional ledgers can be inserted to be used as guard rails.

DIAGONAL BRACE

The diagonal brace is a tubular brace with a C-Pressing at either end to locate to uprights. Note: A half swivel coupler can also be supplied as an alternative to the C-Pressing.

STEEL HOOK ON BOARD

The boards have non-tilt ends to hook onto the ledgers, where they interlock with each other, and a non-slip level surface to form a safe working platform.

STEEL TOE BOARD

This provides a safe platform edge to prevent loose items falling from the platform.

TOE BOARD CLIP

This bracket locates onto the standard to hold a toe board vertically in place.

CONNECTOR

The connector is inserted into the top of the standard to join vertical standards together. External sleeve connectors, either welded to the standards or independently supplied are available.



STANDARD

Standards are manufactured from 48.3 x 3.35 HT scaffold tube. Clusters of four staggered V-Pressings at 90° to each other are situated at 500mm centres along the length of the standard. (External connector can be included).

High Tensile Tube	
48 mm diameter	
Length (mm)	Mass (kg)
4 000	20.5
3 500	17.9
3 000	14.8
2 500	12.3
2 000	9.8
1 500	7.4
1 000	4.9
500	2.5

NOTE: Maximum safe shear load on each V-Pressing is 10kN.



Standard



Ledger

LEDGER

The ledger is manufactured from 48,3 x 2,65 HT scaffolding tube with captive wedge C-Pressing on each end, which locate on the V-Pressings on the standard. The ledgers are normally placed at 2 000mm centres but additional ledgers can be inserted to be used as guard rails.

High Tensile Tube	
48 mm diameter	
Length (mm)	Mass (kg)
2 500	7.9
2 000	6.4
1 500	5.0
1 295	4.4
1 219	4.2
900	3.2
600	2.4



External Connector

Mass 1.2kg

60mm x 4mm wall thickness - external sleeve.



Light Duty Connector

Mass 0.4kg

38mm x 2mm wall thickness. Joins vertical standards together.



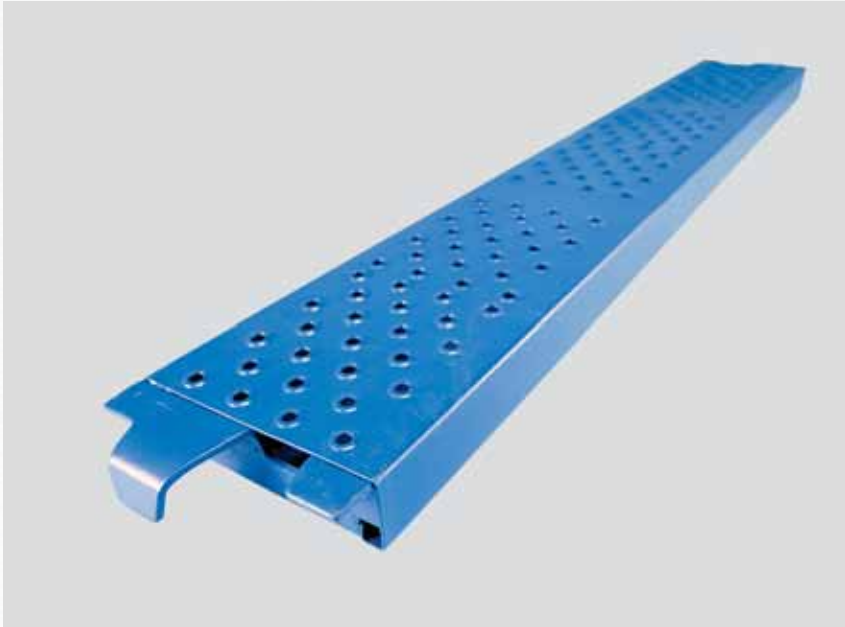

Steel Board	
Length (mm)	Mass (kg)
2 500	17.8
2 000	15.4
1 500	10.6
1 295	9.5
1 219	9.4
900	8.4

The steel boards have non-tilt ends to hook onto the ledgers allowing them to interlock with one another. A non-slip level surface ensures a safe working platform.



Steel Toe Board	
Length (mm)	Mass (kg)
2 500	14.3
2 000	11.6
1 500	8.7
1 295	7.8
1 219	7.2
900	6.3

The toe board provides a safe platform edge to prevent loose items falling from the platform.

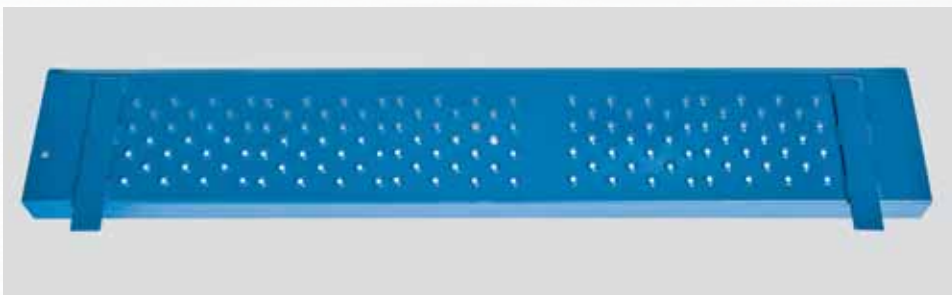

Filler Board	
Length (mm)	Mass (kg)
2 500	15.8
2 000	12.9
1 500	9.2
1 219	8.4
900	5.8

Used as a closure board and secured using a joining clip.



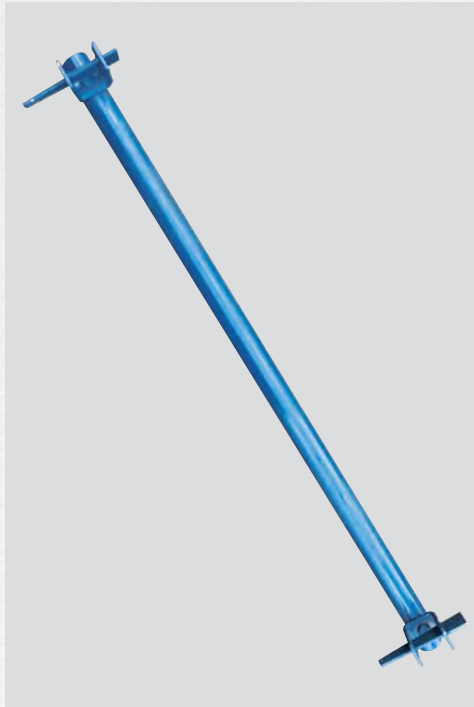

Diagonal Brace		
Size (mm)	C/Centre	Mass (kg)
3 500 x 3 500	4949	19.6
3 500 x 3 000	4610	18.5
3 500 x 2 500	4301	17.3
3 500 x 2 000	4031	16.5
3 500 x 1 500	3808	15.7
3 000 x 3000	4243	16.9
3 000 x 2500	3905	15.7
3 000 x 2 000	3606	14.5
3 000 x 1 500	3354	13.1
2 500 x 2 500	3535	14.4
2 500 x 2 000	3201	13.1
2 500 x 1 500	2915	12.4
2 000 x 2 000	2828	11.7
2 000 x 1 500	2500	10.5
1 500 x 1 500	2120	7.0

A C-Pressing is attached to each end allowing the brace to be attached in any position. A half swivel can be used.



Reinforced Ledger	
Length (mm)	Mass (kg)
2 500	14.4
2 000	11.7

Designed to enable loading over this length of ledger.



Ladder Beam	
Length (mm)	Mass (kg)
6 000 x 300	60.9
3 000 x 300	30.5

A load beam profile fixed to scaffold uprights to allow spanning over a wider distance.



Cantilever Bracket	
Length (mm)	Mass (kg)
900	9.8
600	8.1

The cantilever bracket is used to extend the slab formwork in areas where there is no support from below. It can be used to support a beam or channel. Typical applications are for slab extensions and access work. External sleeve can be included.





DH Coupler
Mass 1.1kg

Used to attach a standard tube to a standard at 90°.



Band and Plate set
Mass 2.9kg

Connects two tubes at right angles.



Swivel Coupler 50 x 50mm
Mass 1.4kg

The coupler has a swivel joint to allow the tube to be connected at the required angle.



Girder Coupler
Mass 1.55kg

Used for attaching scaffold tube to steel girder beam. Should always be used in pairs.



90° Coupler 50 x 50mm
Mass 1.3kg

Clamps scaffold tube at 90° angle.



Toe Board Clip
Mass 2.2kg

Clamps to standard to accommodate toe board.



J Head Spigot
Mass 1.5kg

150mm x 75mm x 6mm
Can take 9" x 3" timber bearer or a 100mm x 50mm steel channel. Used to carry single timber bearers. The spigot fits into the head of the prop.



U Head Spigot
Mass 1.8kg

200mm x 150mm x 8mm
Can take twin timber or a double 100mm x 50mm steel channel. Used to carry two single timber bearers or box floor centres. The spigot fits into the head of the prop.



Base Plate
Mass 1.2kg

The spigot fits into the standard and is used when the standard is erected on a level surface bed.





Base Jack 610 R/O

Base Jack 457 R/O

Mass 610 4.3kg

Mass 457 3.8kg

38mm x 4mm tube.
The base jack is used to accommodate variations in ground levels. Adjustments of 610 or 457 are available.



Solid Base Jack

Mass 7.4kg

38mm Solid bar to accommodate higher loadings and less corrosion.



Swivel Jack

Mass 8.6kg

38mm Solid bar stem.
The swivel jack provides stability on uneven surfaces with 180° rotation for extra flexibility.



U Head Jack 610 R/O

Mass 5.1kg

38mm x 4mm tube
The U Head can take twin timber or a double 100mm x 50mm steel channel.



J Head Jack 610 R/O

Mass 4.9kg

38mm x 4mm tube
The J Head can take a 9" x 3" timber bearer or a 100mm x 50mm steel channel.



STAIRCASE

The standard DRS staircase is a 2.5 x 2.0m module incorporating both a top and bottom landing. The 520mm wide unit can be accommodated in a standard 2.5 x 1.219 tower. The staircase can be fitted with a standard handrail unit and can lead onto a steelboard deck at any 2m level.

LADDERS

The access ladders, which are manufactured using steel flat bar with round bar rungs, provide vertical access up an access tower. These ladders interlock with one another at various intervals and can be secured to the scaffold using standard clamps.

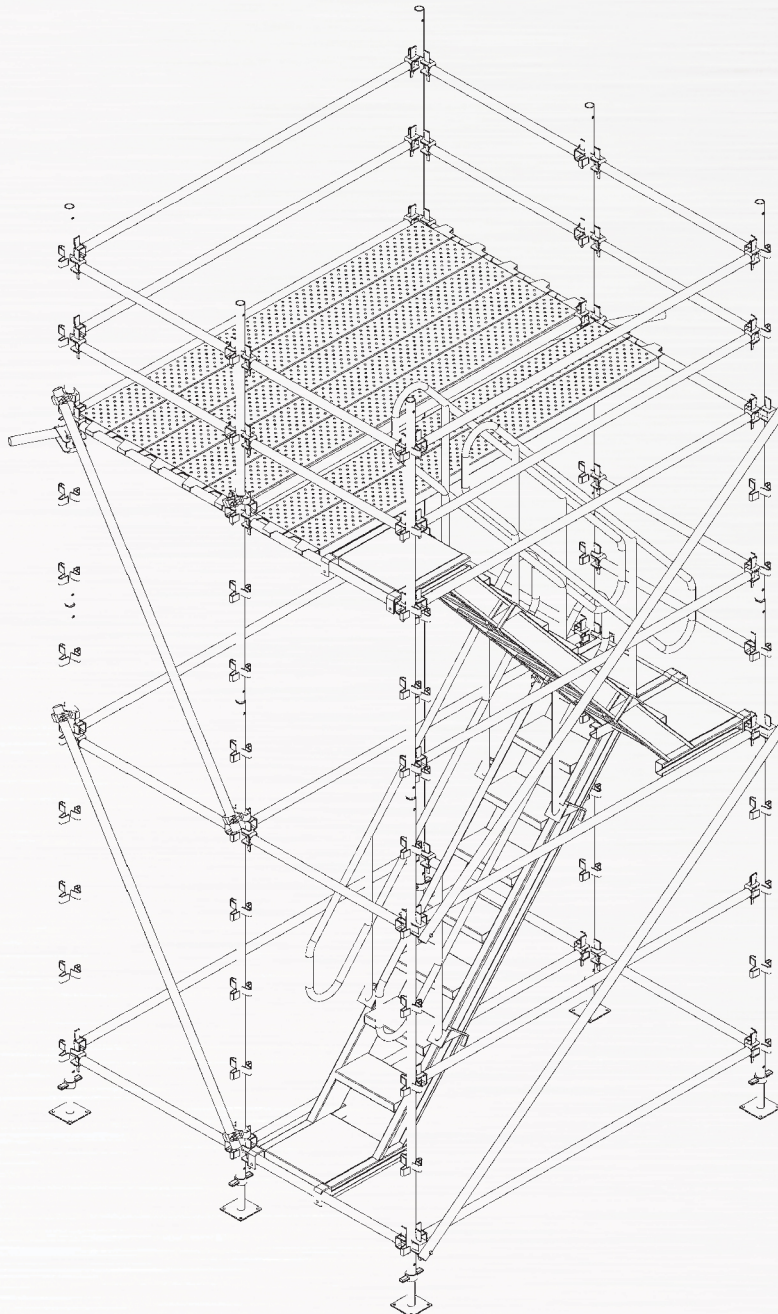

ACCESS SCAFFOLDING



Staircase 2 500 x 2 000 x 520

Mass 54kg

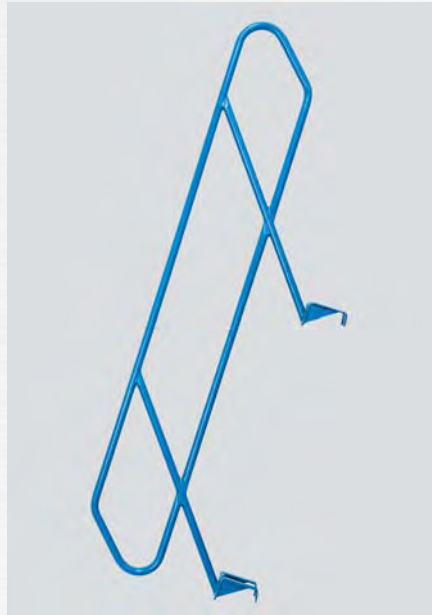

Staircase Handrail

Mass (kg) 16.4kg

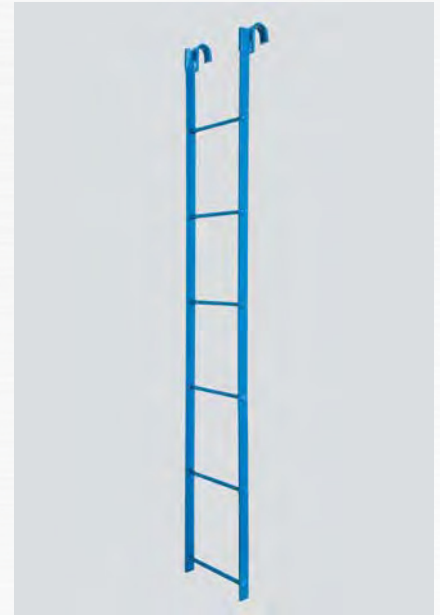

Access Ladder

Length (mm)	Mass (kg)
3 000	23.7
2 000	16.5
1 000	8.7



Staircase and Handrail



Access Door

	Mass (kg)
2 Board	7.0
3 Board	8.5





Scaffold Tube

Mass 3.7kg/m

Tube is high tensile
48.4mm x 3.35mm.
Can be supplied in pre-determined
lengths either straight or radiused.



Pallet

Length (mm) Mass (kg)

870 x 870 93,0

Robust construction for handling
and storing of scaffold products.



Stillage

Length (mm) Mass (kg)

1 200 x 1 200 111,0

Secured bin for handling and
storage of scaffold components.



Stacking of stillages



ESTIMATING CHART USING 3m STANDARDS

(Note: Standards can be manufactured with sleeves eliminating connector requirements)

Notes: Quantities are approximate.

For detailed Design contact DRS Formwork & Scaffolding.

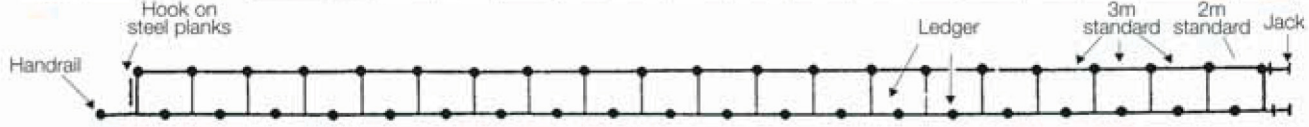

A	B	C
D	E	F

A: 3m Standard
D: 2.5m Ledger

B: 2m Standard
E: 1.219m/1.295m Ledger

C: Connectors
F: 2.5m x 2.0m Diagonal Brace

Height to top of working platform (metres)	2.5m		5.0m		7.5m		10.0m		12.5m		15.0m		17.5m		20.0m		22.5m		25.0m												
	No of 2m lifts	Length of Scaffold	Length of Scaffold	Length of Scaffold	Length of Scaffold	Length of Scaffold	Length of Scaffold	Length of Scaffold	Length of Scaffold	Length of Scaffold	Length of Scaffold	Length of Scaffold	Length of Scaffold	Length of Scaffold	Length of Scaffold	Length of Scaffold	Length of Scaffold	Length of Scaffold	Length of Scaffold	Length of Scaffold											
4.0m	2	4	4	5	7	6	10	8	7	13	10	8	16	12	9	19	14	10	22	16	11	25	18	12	28	20	13	31	22		
6.0m	3	4	8	7	10	11	10	12	14	13	14	17	16	20	19	18	23	22	20	26	25	22	29	28	24	32	31	26	35		
8.0m	4	12	8	17	1	12	22	2	16	27	3	20	32	4	24	37	5	28	42	6	32	47	7	36	52	8	40	57	9	44	
10.0m	5	12	4	12	17	7	18	22	10	24	27	13	30	32	16	36	37	19	42	22	48	47	25	54	52	28	60	57	31	66	
12.0m	6	12	14	5	24	20	5	36	26	5	48	32	5	60	38	10	72	44	10	84	50	10	96	56	10	108	62	10	120	68	10
14.0m	7	14	16	6	28	23	6	42	30	6	56	37	6	70	44	12	84	51	12	98	58	12	112	65	12	126	72	12	140	79	12
16.0m	8	16	18	7	32	26	7	48	34	7	64	42	7	80	50	14	96	58	14	112	66	14	128	74	14	144	82	14	160	90	14
18.0m	9	20	20	8	36	29	8	54	38	8	72	47	8	90	56	16	102	65	16	126	74	16	144	83	16	162	92	16	180	101	16
20.0m	10	20	22	9	40	32	9	60	42	9	80	52	9	100	62	18	120	72	18	140	82	18	160	92	18	180	102	18	200	112	18
22.0m	11	22	24	10	44	35	10	66	46	10	88	57	10	110	68	20	132	79	20	154	90	20	176	101	20	198	112	20	220	123	20
24.0m	12	28	24	26	48	38	11	72	50	11	96	62	11	120	74	22	144	86	22	168	98	22	192	110	22	216	122	22	240	134	22
26.0m	13	36	28	32	52	41	12	78	54	12	104	67	12	130	80	24	156	93	24	182	106	24	208	119	24	234	132	24	260	145	24
28.0m	14	36	30	36	56	44	13	84	58	13	112	72	13	140	86	26	168	100	26	196	114	26	224	128	26	252	142	26	280	156	26
30.0m	15	36	30	40	60	47	14	90	62	14	120	77	14	150	92	28	180	107	28	210	122	28	240	137	28	270	152	28	300	167	28
		32	34	15	64	50	15	96	66	15	128	82	15	160	98	30	192	114	30	224	130	30	256	146	30	288	162	30	320	178	30
Adj. Base Jacks		4	4	6	6	8	8	8	8	10	10	10	12	12	14	14	14	14	16	16	16	18	18	18	20	20	20	22	22	22	
2.5m H/O Boards		5	5	10	10	15	15	15	15	20	20	20	25	25	30	30	30	30	35	35	35	40	40	40	45	45	45	50	50	50	
No. of 2.5m Bays		1	1	2	2	3	3	3	3	4	4	4	5	5	6	6	6	6	7	7	7	8	8	8	9	9	9	10	10		
Length of Scaffold		2.5m	2.5m	5.0m	5.0m	7.5m	7.5m	10.0m	10.0m	12.5m	12.5m	15.0m	15.0m	17.5m	17.5m	20.0m	20.0m	22.5m	22.5m	25.0m	25.0m	25.0m	25.0m	25.0m	25.0m	25.0m	25.0m	25.0m	25.0m	25.0m	



SELFLOCK SYSTEM

SELFLOCK TOWER

Selflock frames are light and easy to handle and are ideal to gain quick access to elevated positions. Towers can be erected in a short time by two unskilled workers.

Uses of towers as access

- Electrical work
- Maintenance
- Painting
- Plumbing
- Plastering
- Column erection

Allowable tower heights

Below is a list of the recommended maximum free standing heights allowed based on maximum base-to-height ratio

- Inside static towers 4 x min. base dimension
- Inside mobile towers 3.5 x min. base dimension
- Outside static towers 3.5 x min. base dimension
- Outside mobile towers 3 x min. base dimension

Tying in

When the safe base-to-height ratios are being exceeded or there are high lateral loads, the tower should be tied securely to the structure with scaffold tubes and fittings.

Note

Towers can extend to 30m (150') if tied in correctly.

Mobile Towers

Mobile tower castors must be locked when the tower is in use. The tower can be moved on jack castors which must be locked when the tower is in use.

The following items are the most common components used with the system.

Frames		
Size (mm)	(ft)	Mass (kg)
3 048 x 914	(10 x 3)	20.35
2 134 x 914	(7 x 3)	14.45
1 524 x 914	(5 x 3)	12.54
Steel Boards		
Size (mm)	(ft)	Mass (kg)
3 048	10	21.69
2 134	7	15.39
1 524	5	11.53
Plan Braces		
Size (mm)	(ft)	Mass (kg)
3 048 x 3 048	(10 x 10)	7.24
3 048 x 2 134	(10 x 7)	6.32
3 048 x 1 524	(10 x 5)	5.81
2 134 x 2 134	(7 x 7)	5.21
2 134 x 1 524	(7 x 5)	4.62
1 524 x 1 524	(5 x 5)	3.90
Tie Bars		
Size (mm)	(ft)	Mass (kg)
3 048	10	6.97
2 134	7	5.15
1 524	5	3.93
Accessories		
Size (mm)		Mass (kg)
Base plate		0.65
Knee brace		4.40
Spigot castor		5.40
35mm Base jack		6.5

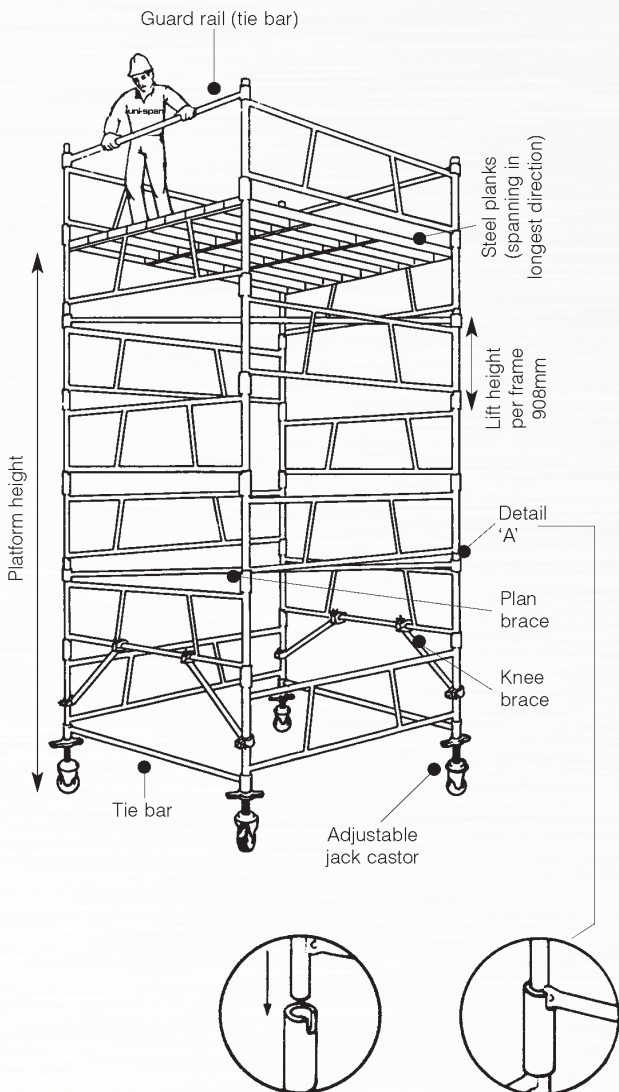

LOCKING OF FRAMES (DETAIL "A")

Loading: Maximum permissible loading = 160kg/m²

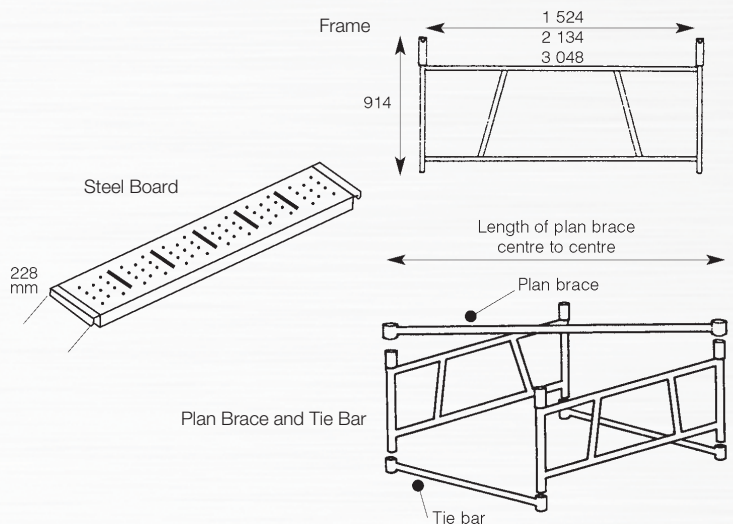



**WALL
SYSTEM**



THE WALL SYSTEM

The DRS system consists of all steel economy panels. These are available in a combination of sizes from 75mm to 600mm wide and 900mm to 3000mm long. Special sizes can also be made to order.

The panels are joined by wedge sets which are inserted through slots in the punched flat which forms the edge of the panel.

The panels are aligned by either tube or channel walers which are clamped to the panels with B-Clamps or C-Clamps.

For heavy duty concrete work, form soldiers are used. The panels are then gangformed and crane handled.

The panels are tied together to form parallel faces using tie systems. The versatile panel system can be used to construct: walls, columns, beams, culverts, bridges and pile caps.

The panel system consists of 6 basic elements: Steel economy panels, tubular or channel walers, wedge sets, tie systems, push-pull props or plumbing brackets and access brackets.



ECONOMY PANEL

Economy panels are an advanced multi-purpose formwork system because:

- Stiffeners are built into the panel, therefore only two scaffold tube or channel walers are required for alignment
- Minimum clamps are required
- Rapid assembly with wedge sets
- Can easily be erected by unskilled labour
- Accommodates any tie system
- Durable steel face plate cannot be damaged by vibrators or penetrated by the reinforcing steel
- The automatic precision on assembly, results in 100% dimensional accuracy of the finished concrete
- Multi use - walls and decking

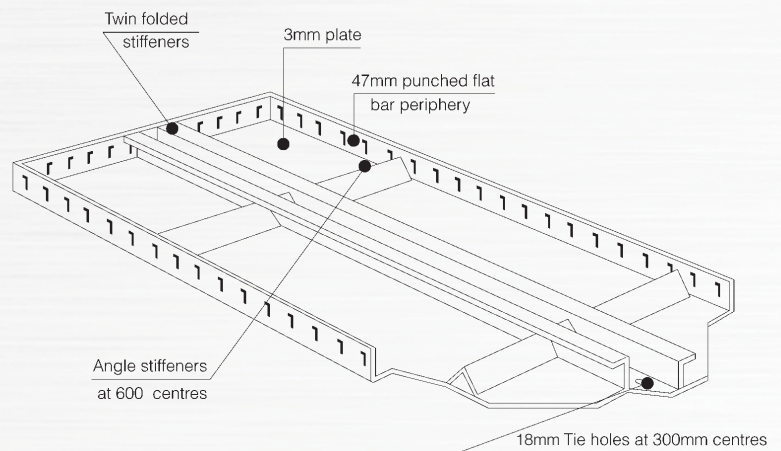

The economy panel's main application is for vertical walling. It can also be used for horizontal beam soffits and for slabs where an "off the shutter" finish is required.



75 - 300mm wide

Length	Width	Mass	Length	Width	Mass	Length	Width	Mass	Length	Width	Mass
mm	mm	kg	mm	mm	kg	mm	mm	kg	mm	mm	kg
3 000	x 600	78.9	2 700	x 600	70.6	2 400	x 600	63.5	2 100	x 600	55.2
3 000	x 500	70.2	2 700	x 500	61.0	2 400	x 500	56.5	2 100	x 500	48.7
3 000	x 450	65.8	2 700	x 450	59.0	2 400	x 450	53.0	2 100	x 450	46.1
3 000	x 400	59.6	2 700	x 400	53.4	2 400	x 400	43.4	2 100	x 400	41.7
3 000	x 350	55.3	2 700	x 350	49.5	2 400	x 350	38.8	2 100	x 350	38.7
3 000	x 300	46.4	2 700	x 300	41.9	2 400	x 300	37.4	2 100	x 300	32.8
3 000	x 250	39.9	2 700	x 250	34.8	2 400	x 250	33.1	2 100	x 250	27.4
3 000	x 230	38.6	2 700	x 230	32.7	2 400	x 230	31.4	2 100	x 230	26.8
3 000	x 225	38.0	2 700	x 225	32.5	2 400	x 225	31.0	2 100	x 225	26.7
3 000	x 200	32.8	2 700	x 200	29.7	2 400	x 200	28.2	2 100	x 200	23.4
3 000	x 150	29.1	2 700	x 150	26.2	2 400	x 150	23.3	2 100	x 150	20.5
3 000	x 100	18.8	2 700	x 100	17.0	2 400	x 100	15.1	2 100	x 100	13.2
3 000	x 75	18.7	2 700	x 75	16.9	2 400	x 75	11.7	2 100	x 75	12.3
1 800	x 600	48.2	1 500	x 600	39.9	1 200	x 600	32.9	900	x 600	25.9
1 800	x 500	42.6	1 500	x 500	35.0	1 200	x 500	30.1	900	x 500	22.2
1 800	x 450	40.2	1 500	x 450	33.3	1 200	x 450	27.4	900	x 450	21.4
1 800	x 400	36.3	1 500	x 400	30.1	1 200	x 400	24.2	900	x 400	18.4
1 800	x 350	33.7	1 500	x 350	27.9	1 200	x 350	22.0	900	x 350	17.1
1 800	x 300	28.3	1 500	x 300	23.7	1 200	x 300	19.3	900	x 300	14.7
1 800	x 250	25.2	1 500	x 250	20.1	1 200	x 250	16.2	900	x 250	13.5
1 800	x 230	23.4	1 500	x 230	19.9	1 200	x 230	15.9	900	x 230	12.2
1 800	x 225	23.0	1 500	x 225	19.3	1 200	x 225	15.6	900	x 225	11.9
1 800	x 200	20.2	1 500	x 200	17.1	1 200	x 200	12.2	900	x 200	10.8
1 800	x 150	17.7	1 500	x 150	14.8	1 200	x 150	12.0	900	x 150	9.1
1 800	x 100	11.4	1 500	x 100	9.5	1 200	x 100	7.2	900	x 100	5.9
1 800	x 75	10.5	1 500	x 75	9.1	1 200	x 75	5.5	900	x 75	5.0





Clip & Wedge Set
 Mass 0.1kg
 Connects panels together.



Heavy Duty Wedge Set
 Mass 0.2kg
 Connects panels together.



Wedge Assembly
 Mass 1.5kg
 Connects column boxes and uniform panels together.

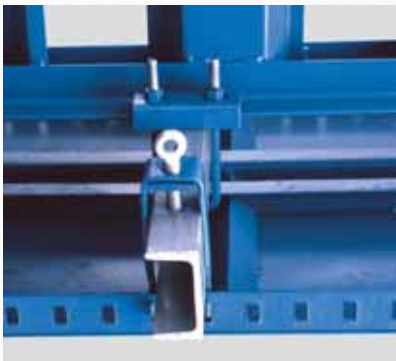

Working C-Clamp
 Connects channel to economy panel.



B-Clamp
 Mass 0.8kg
 For rapid connection of tube to panels for accurate alignment.



C-Clamp
 Mass 1.1kg
 For rapid connection of channel to panels for accurate alignment.



Form Panel Clamp
 Mass 0.4kg
 Connects form soldiers to panels.



Tube Waler Clamp
 Mass 0.6kg
 Connects tube to form soldier.



Channel Waler Clamp
 Mass 0.9kg
 Connects channel to form soldier.



INTERNAL CORNER PANEL

ICP's come in the full range of EF Panel lengths forming 150 x 150mm internal corners. They can be used for the internal corner between a drop beam and slab soffit as well as vertical corners.

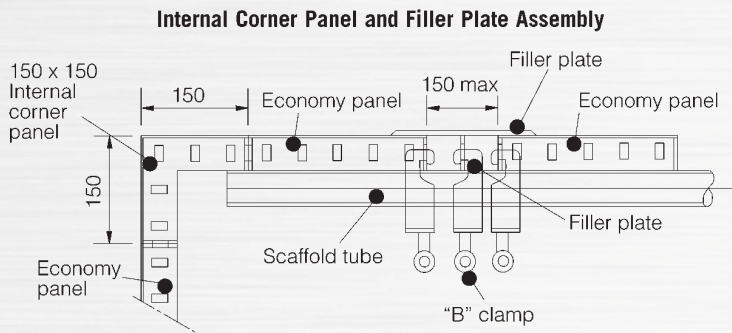

Size (mm)	Mass (kg)
3 000 x 150 x 150	39.1
2 700 x 150 x 150	35.3
2 400 x 150 x 150	33.2
2 100 x 150 x 150	31.5
1 800 x 150 x 150	25.0
1 500 x 150 x 150	23.8
1 200 x 150 x 150	16.2
900 x 150 x 150	12.4

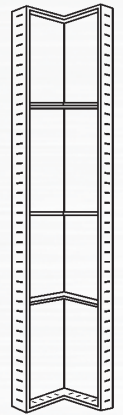

FILLER PLATE

Filler plates fill in gaps when using non-standard modules and facilitate stripping in confined areas.

Size (mm)	Mass (kg)
3 000 x 200	15.8
2 700 x 200	14.3
2 400 x 200	12.7
2 100 x 200	11.1
1 800 x 200	9.5
1 500 x 200	8.0
1 200 x 200	6.4
900 x 200	4.8



EXTERNAL CORNER ANGLE

ECA's have a fixed size of 50mm x 50mm and are used to connect the panels at a 90° angle on walls or columns.

Size (mm)	Mass (kg)
3 000 x 50 x 50	11.3
2 700 x 50 x 50	10.2
2 400 x 50 x 50	9.1
2 100 x 50 x 50	7.9
1 800 x 50 x 50	6.8
1 500 x 50 x 50	5.7
1 200 x 50 x 50	4.5
900 x 50 x 50	3.4



INTERNAL SPLAY PANEL

Size (mm)	Mass (kg)
1 200 x 200 x 100 x 135° Internal Splay	15.1
900 x 200 x 100 x 135° Internal Splay	11.6

EXTERNAL SPLAY PANEL

Size (mm)	Mass (kg)
1 200 x 200 x 100 x 135° External Splay	15.1
900 x 200 x 100 x 135° External Splay	11.6

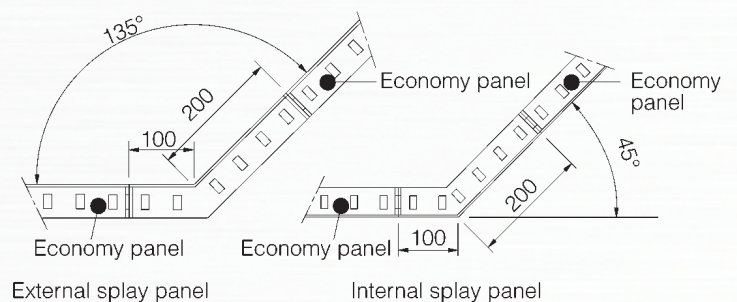

WALLING SYSTEM - ERECTION PROCEDURE

For Crane Handled Gangform System

1. The panels are laid out on a flat surface and joined with wedge sets.
2. Tubes and/or channels are attached to the panels with B-Clamps or C-Clamps.
3. The assembled wall is lifted into position either manually or with a crane.
4. Ties are inserted through the tie holes, the plastic tube having been cut to the correct length in accordance with the width of the concrete wall to be poured.
5. Push-pull props are secured to the ground and to the gangform and are adjusted to achieve accurate vertical plumbing.

Assembly of external and internal wall shutters.

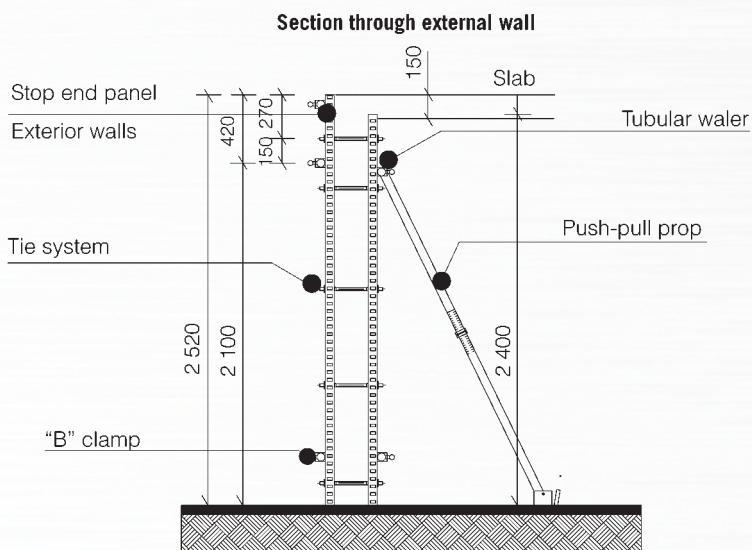
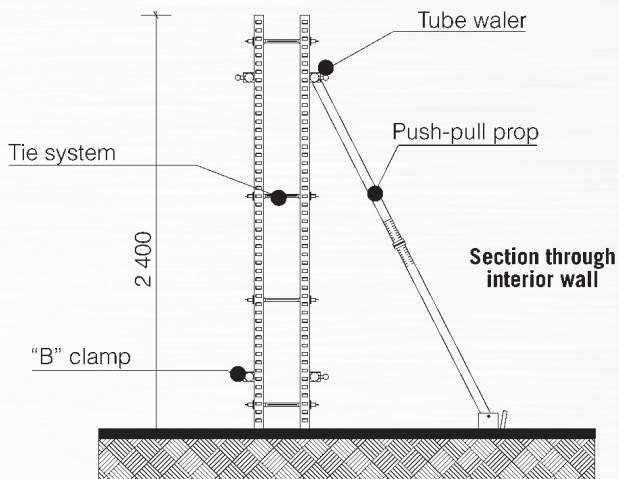

Steel faced economy panels and single channel aligning walers including form soldiers complete with plumbing and access bracket fittings.

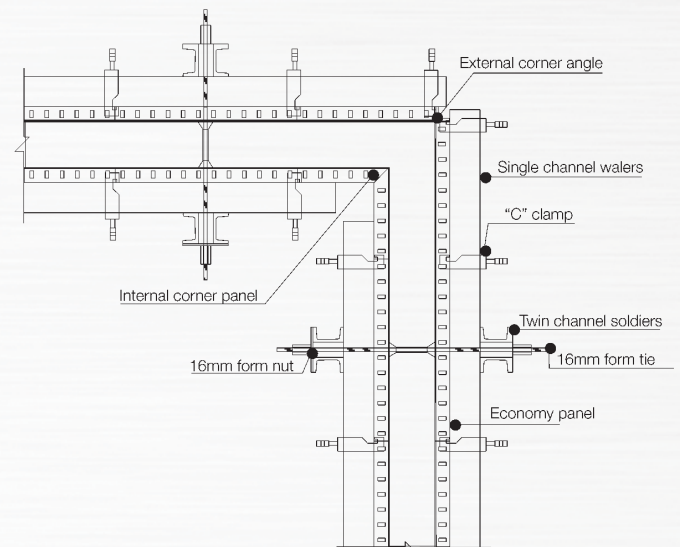

Typical wall plan showing a panel layout of economy panels and internal corner panels using aligning channels with ties through the panel onto twin channel soldiers.



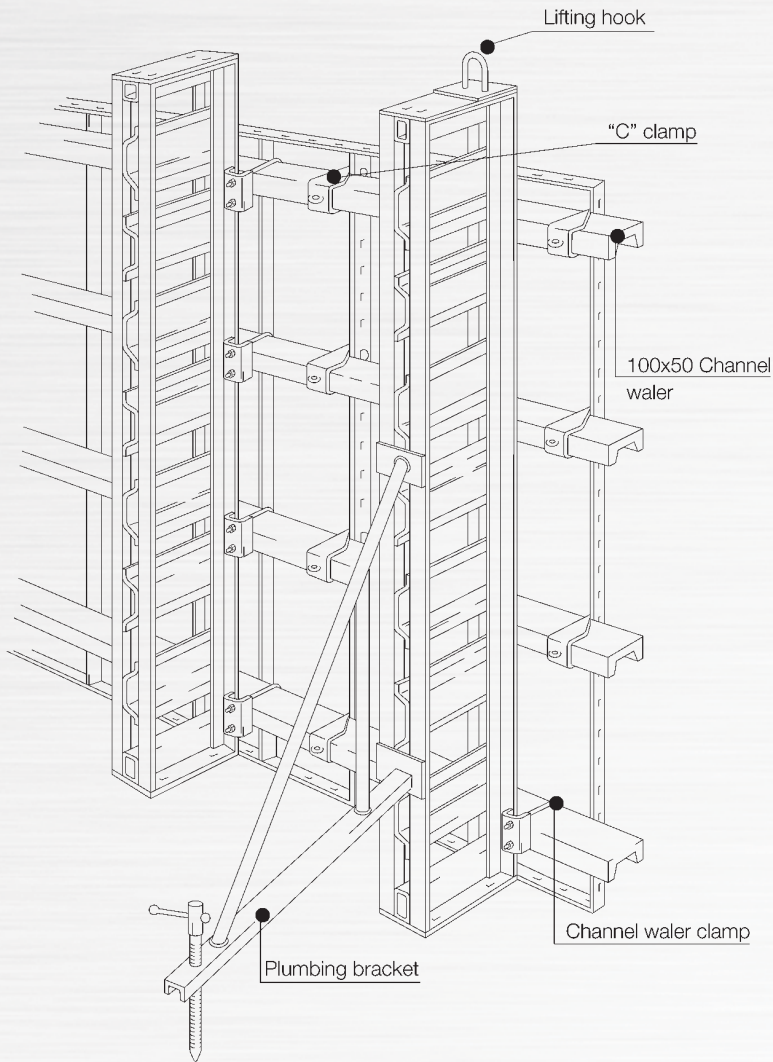

FORM SOLDIERS

The form soldier is used for gangform wall shutters where crane handling is available. The shutter becomes a precision unit ideal for perfect "off the shutter" finishes.

- Structural web system enables ties and anchors to be positioned anywhere in its height.
- Ideally suited for climbing formwork.
- Can be used as bearers for heavy structures.

Form soldiers have plan dimensions of 300mm deep x 150mm wide.

Properties of major axis:

Moment of inertia $3\,598\text{cm}^4$

Section modulus 240cm^3

Allowable tie load 85kN at any point.

Form soldier $I = 3598\text{cm}^4$ $Z = 240\text{cm}^3$

Size (mm)	Mass (kg)
3 600	82.5
3 300	76.2
3 000	69.9
2 700	63.5
2 400	57.3
2 100	51.1
1 800	44.8
1 500	38.5
1 200	32.2



Form soldier gangform assembly

FORM BOTTOM PLATE

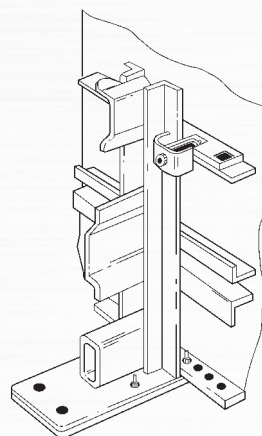

Panel clamp for connecting horizontal steel panels directly to the face of the form soldier.

Mass 0.26kg

Bottom plate facilitates fixing or lifting. This bolts directly to the bottom of the form soldier and panels.

Mass 2.25 kg



GANGFORMS

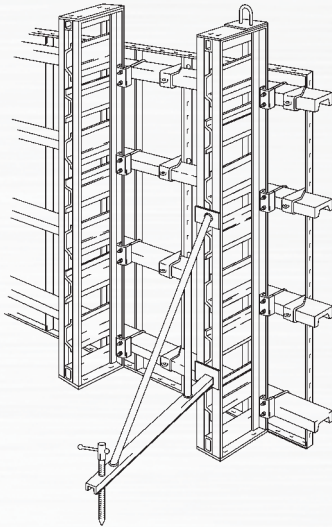

An assembled gangform shutter with economy panels. Vertically assembled. Horizontal 100 x 50 channel walers are C-Clamped to the panels and fastened to the form soldiers with channel waler clamps.

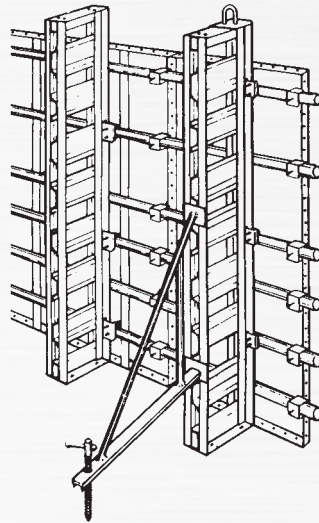

An assembled gangform shutter with economy panels. Vertically assembled. Standard scaffold tube is B-Clamped to the panels and fastened to the form soldiers with tube waler clamps.

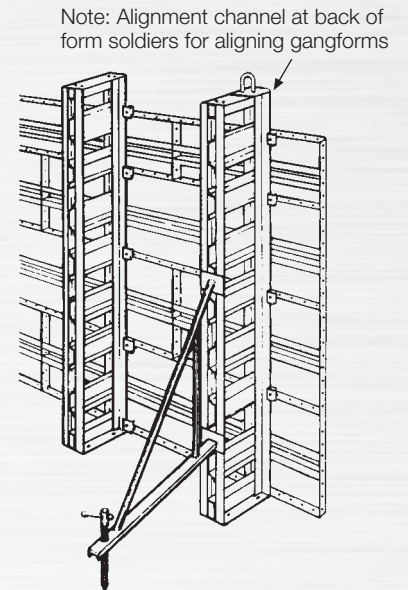

Panels are assembled horizontally and fastened to the form soldier with form panel clamps. Top and bottom aligning channels are used on the form soldier to give strength to the form.



PUSH-PULL PROP

The push-pull prop has a double collar, which enables the walls and columns to be accurately plumbed. Used on walls and column boxes for speedy erection and ease of alignment.

Description	Size (mm)	Mass (kg)
No 1	1 676 - 3 124	19.6
No 2	1 981 - 3 352	20.5
No 3	2 590 - 3 962	22.7
No 4	3 200 - 4 876	26.9



FLEXFORM PANELS

Flexform panels are used for the construction of curved walls with a radius of between 3 and 20 metres.

The tube is radiused to the required diameter and then the flexform panel is fastened to the tube to create the circular shutter required. Filler panels are used on the external shutter to accommodate the difference in the outside circumference.

The panel has a 2mm steel face plate and is attached to the radiused tube with B-Clamps.

Size (mm)	Mass (kg)
1 500 x 600	26.5
1 500 x 450	22.7
1 200 x 600	21.7
1 200 x 450	15.7
900 x 600	16.0
900 x 450	11.9

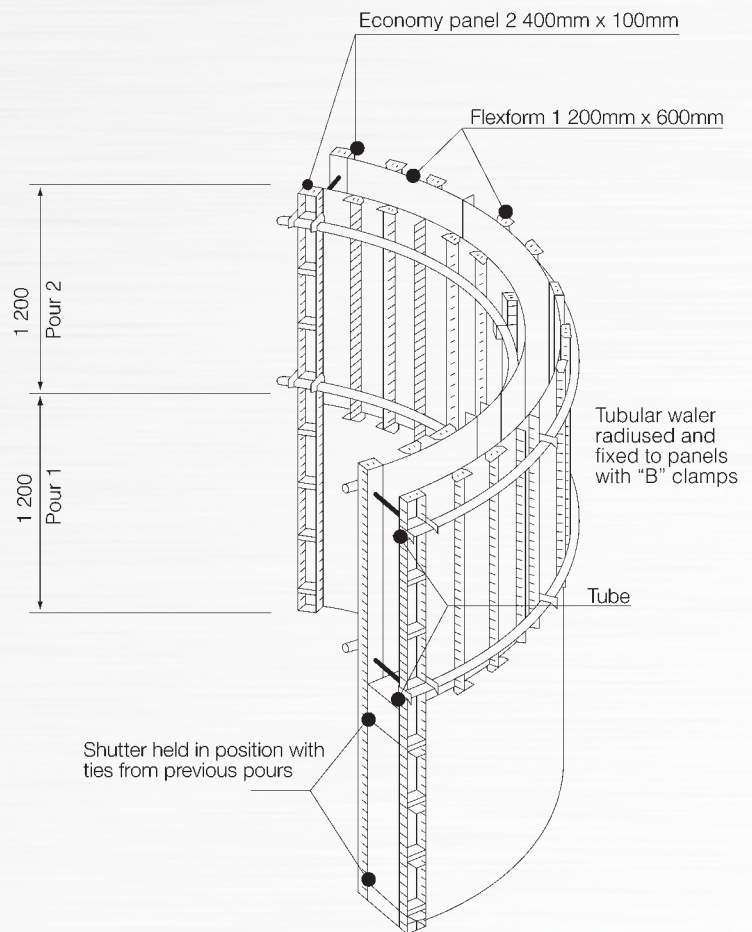

Typical section of a climbing wall shutter

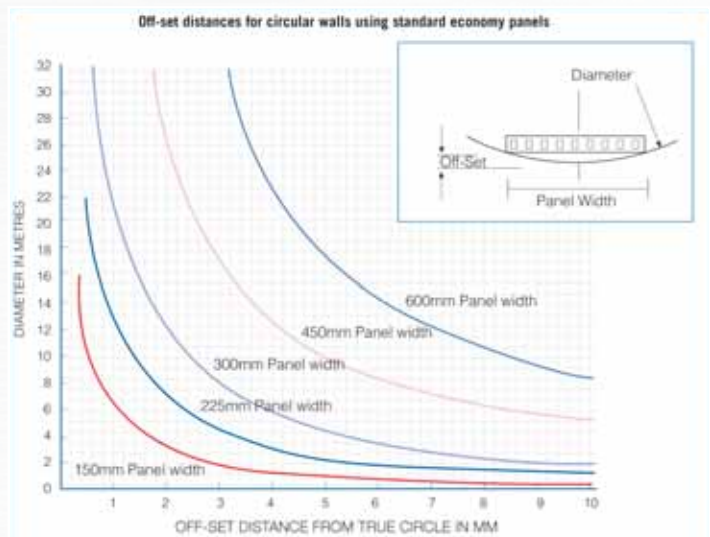

STANDARD WALL TIE ASSEMBLY

All items are recoverable after casting, except for the plastic tube.

Diameter (mm)	kg/m	Load kN
20	2.5	120
16	1.6	84
12	0.8	40

Factor of safety 1.9

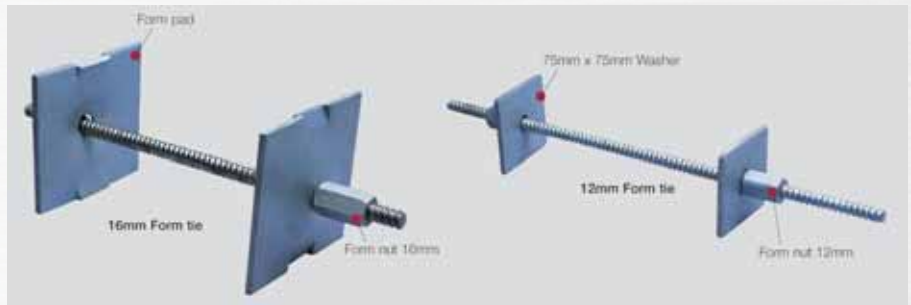

ROUND BAR TIE

Positive stop-in cone gives accurate wall size.

Round bar ties are similar to crimp ties except that the bars are made of 12, 20 or 24mm mild steel bars. (Also available as water ties).

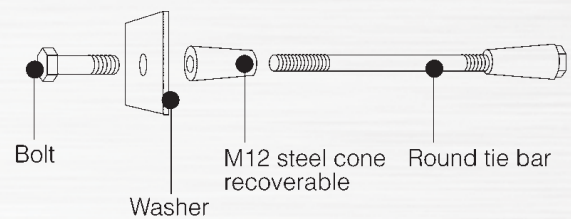

WATER STOP



15mm Tie Rod



Water Stop



Combi Wing Nut

FERRULE TIE SYSTEM

All components fully recoverable except for the ferrule tube.

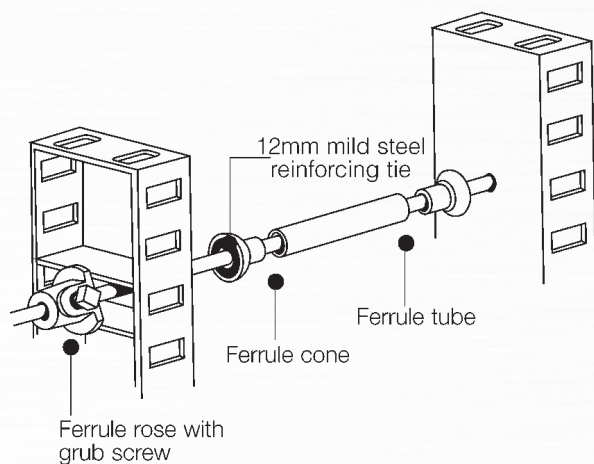

FERRULE TIGHTENER JACK

To tension rods prior to tightening the ferrule grub screw.

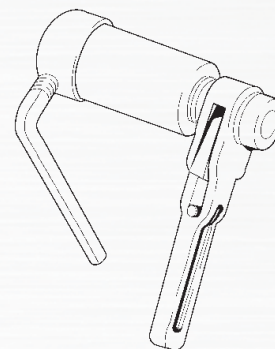

ANCHOR SCREWS

Recoverable anchor screws are used for fixing brackets and formwork to concrete.

Size (mm)	Load at 5MPa kN	Tie load kN	Concrete MPa	Mass (kg)	Outside diameter (mm)	Maximum depth of thread (mm)
M36 x 430	110	215	16	1.6	58	64
M24 x 280	60	95	12	1.1	39	50
M20 x 200	30	50	10	0.9	39	38
M20 x 120	10	50	19	0.6	39	38

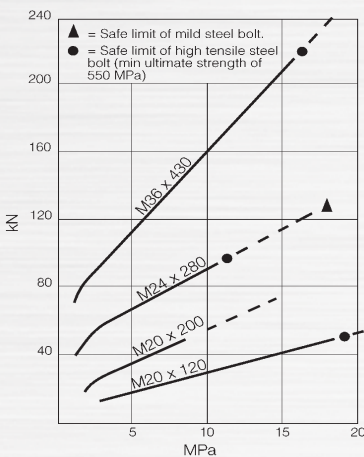

Anchor screw bolted onto standard economy panel.

Safe loading capacities are based on a load factor of 1.5:1 on ultimate pull-out values.

CAUTION:

Although graph is based on actual tests, it is given as a general guide only. Where warranted a greater safety factor should be used.

EXTRACTOR TOOL

The anchor screws are cast in and are easily removed using an extractor tool.



PLASTIC SHUTTER BUTTON

Used for closing ferrule tie holes in steel or timber shutters. Available for different size holes. Inexpensive and robust.



PLASTIC CORNER FILLET

50mm lip of plastic corner with slots to attach to economy panels with wedge sets, and wedge assemblies for attaching to columns. When dismantling formwork, plastic corners come off automatically and are ready for re-use.

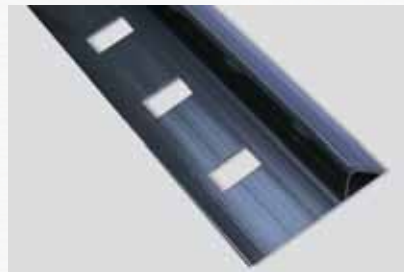

	a(mm)	b (mm)	c (mm)
	10	10	14
	15	15	17
	18	18	25
	20	20	28
	25	25	35

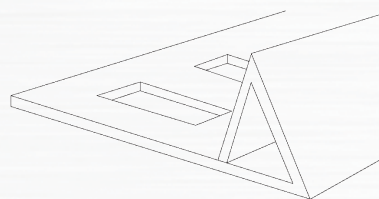

The 20mm x 20mm fillet

GROUTEX

A self-adhesive polyurethane foam sealing strip which prevents grout loss through joints in formwork.



PLASTIC FERRULE TUBING

Plastic tubing replaces more expensive materials. Used to facilitate recovery of thru ties. Supplied in up to 3m lengths.

PUSH-ON PLASTIC CONE

To be attached to each end of ferrule tubing. Can easily be extracted from a concrete structure for re-use. The push-on cone forms a chamfered recess in concrete structures for ease of subsequent grouting. This prevents grout penetrating into ferrule tubing during casting of concrete.



CLIMBING SYSTEM

DRS gangform climbing system is crane handled and fixed to the concrete with anchor screws. The plumbing bracket has an adjustment screw which is used for vertical alignment. The hanging bracket provides a safe working platform for grouting and removal of lower anchors.

Access brackets provide for a three board working platform 685mm wide. The access bracket can be attached to the form soldier at the required position.

Plumbing Bracket

The plumbing bracket has two attachment points 1200mm apart to bolt the bracket vertically to the form soldier. An adjustment screw which extends 900mm from the form soldier is used for vertical alignment.

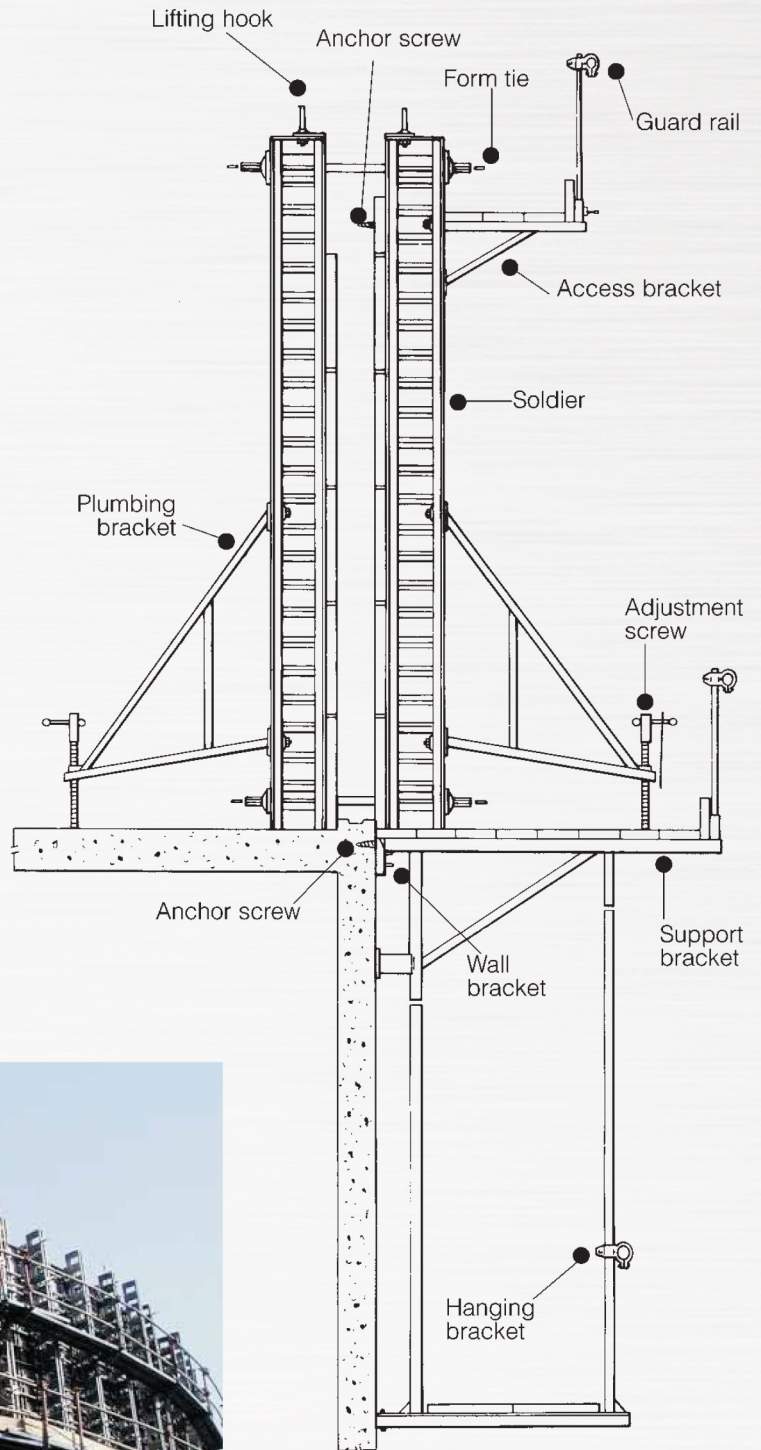



COLUMN BOXES

COLUMN BOXES

ECONOMY PANEL COLUMN BOX

Economy panels can be perfectly adapted for the construction of square or rectangular columns.

Only 4 different components are required:

- Economy panels in various sizes
- External corner angles
- Column wedge sets
- Push-pull props

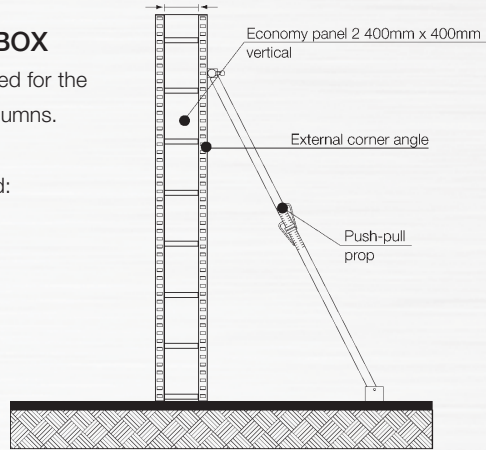

STANDARD CIRCULAR COLUMN

Various sizes can be manufactured to suit column size requirements.

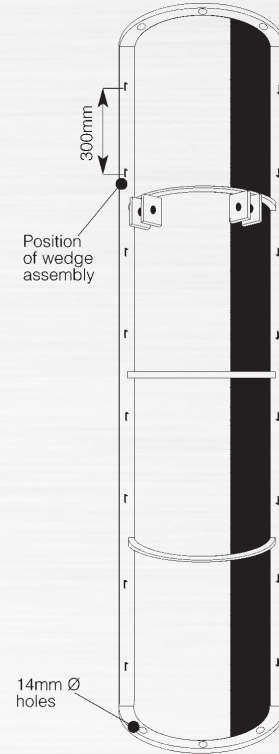

Plan view of column
400mm x 400mm

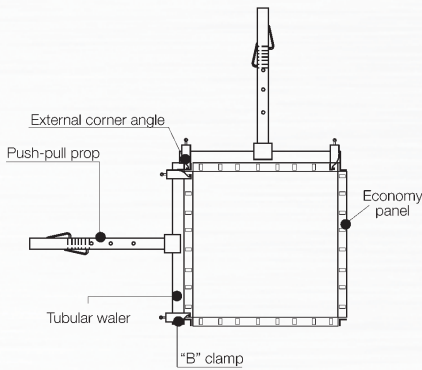

Plan view of column
800mm x 200mm

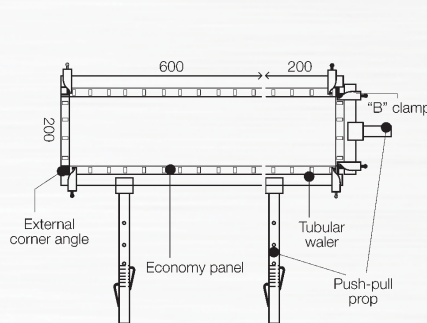

Mushroom heads can be attached to the column boxes.

"A" TYPE COLUMN BOX

"A" type column boxes are purpose made with 3mm / 4mm steel face plate for maximum durability and client specification. Wedge assemblies used for easy connection, fast erection and accurate assembly. Built-in corners ensure that the boxes are self-squaring. Height: supplied in increments of 300mm Width: available in all sizes from 150mm

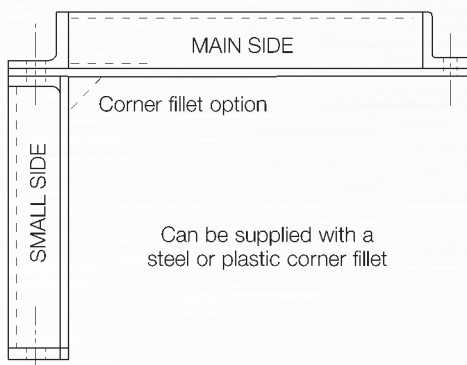

To form square or rectangular columns where square corners are required.

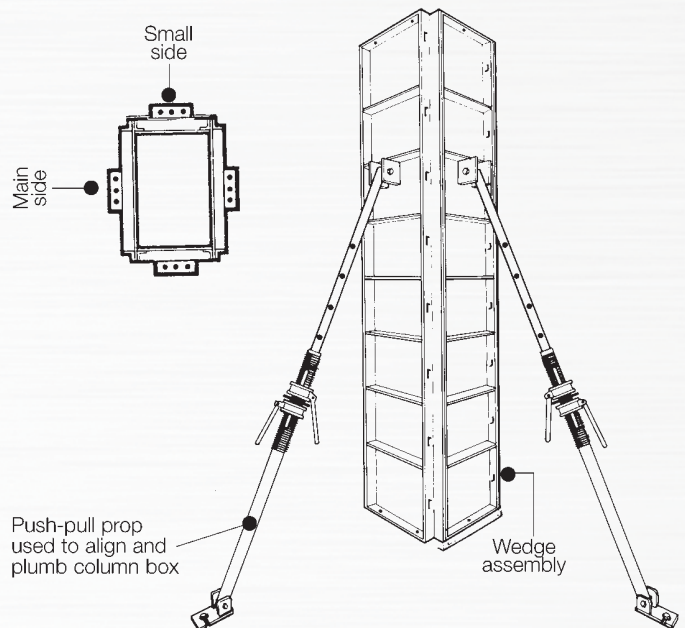



SLAB SYSTEM

DRS all-steel kwikstrip decking system is fast to erect, easy to handle and has only six basic components.

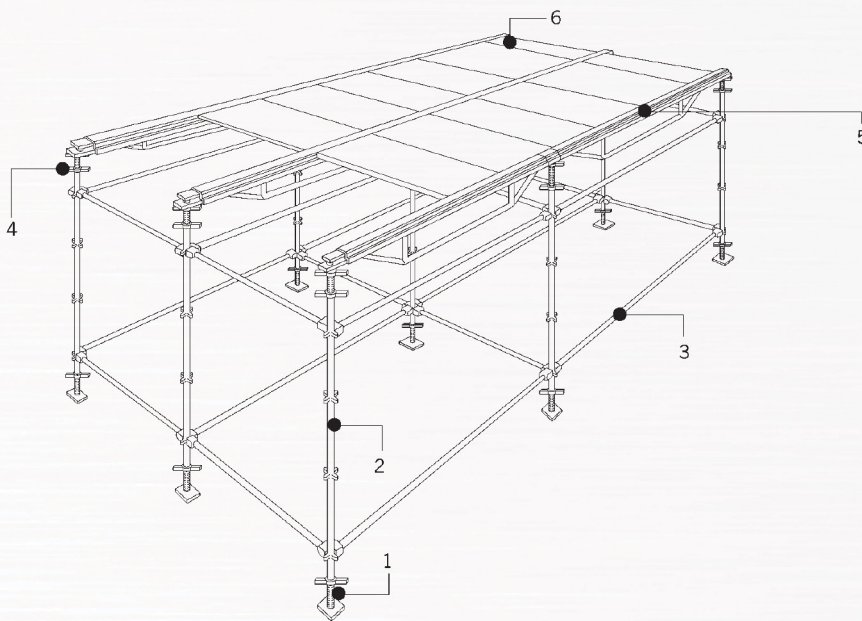

THE SYSTEM

The complete modular system enables easy erection and stripping.

After three days the panels can be stripped leaving the support work, i.e. jacks, standards and ledgers, in place until the concrete has cured.

The components can be packed into pallets to allow for easy transportation.

The system consists of 6 basic components:

- 1 Base Jack
- 2 Standard
- 3 Ledger
- 4 Double-headed jack
- 5 Kwikstrip beam
- 6 Deck panel



KWIKSTRIP SYSTEM

This system allows the slab formwork to be stripped only three days after concrete has been poured. The double-headed jack allows the support work to remain in place thereby avoiding re-propping.

PHASE 1

Complete slab and support system erected.

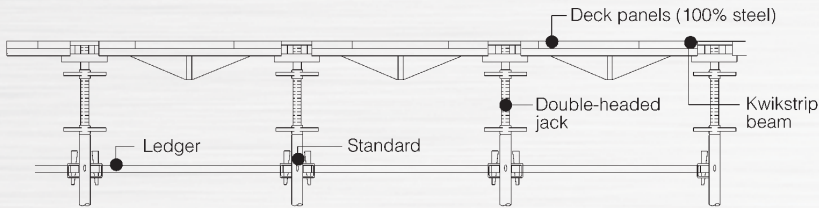

PHASE 2

Reinforcing steel placed and concrete poured.

One day after concreting the second set of support can be erected on the floor above.

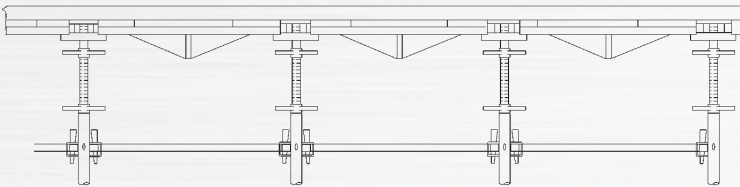

PHASE 3

After three days deck panels and kwikstrip beams are stripped without removing the support (A double set of support is supplied).

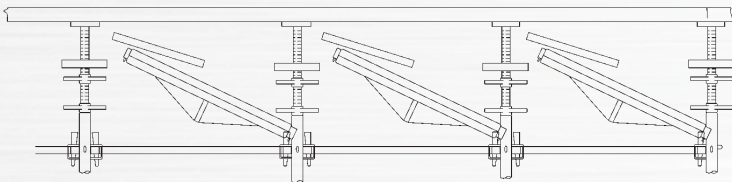

Features of the kwikstrip system

- Maximum utilisation of the equipment
- Eliminates any deflections of the slab
- No re-propping required
- Can be used with coffer and troughs.

After stripping level 1 the panels and kwikstrip beams can immediately be placed on the second set of support previously erected on level 2.

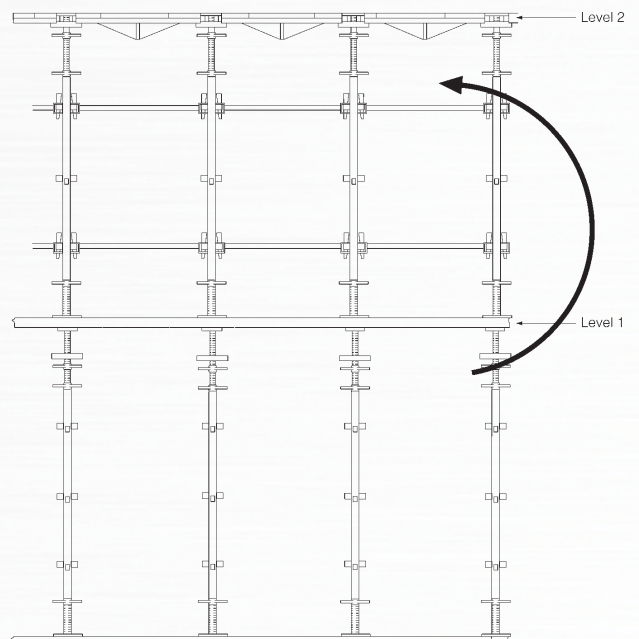



DOUBLE-HEADED JACK

The top collar can be wound down to release the beams and panels only three days after pouring of concrete.

Tube 38mm diameter x 4mm

Thread 610 R/O

Mass 7.7kg

LEDGER

The ledger is manufactured from 48,3 x 2,65 HT scaffolding tube and has a captive wedge assembly which locates into the lug on the standard.

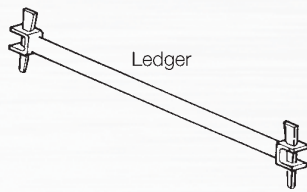

Double-headed jack

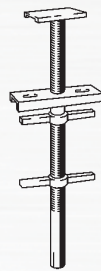

Standard

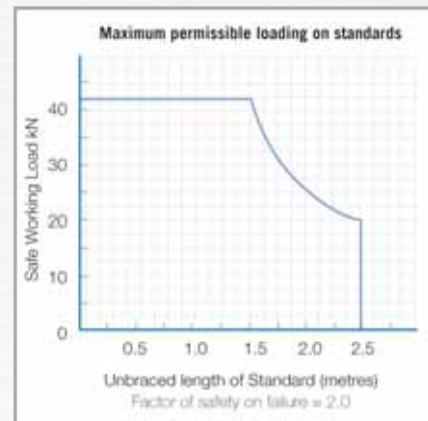
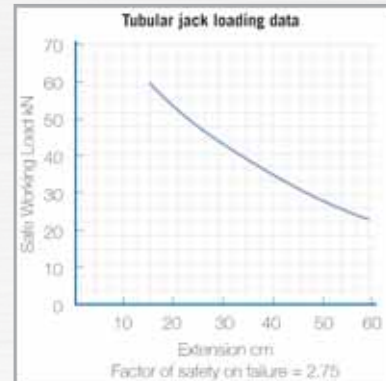
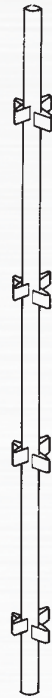

STANDARD

The standard tube is manufactured from 48,3 x 3,35 HT scaffolding tube and has staggered lugs at 500mm centres to enable ledgers to be attached where required. Each standard takes a load of four tons with ledgers placed in 4 directions at a maximum of 1.5m centres and can be joined by a connector.

High Tensile Tube 48 mm diameter	
Length (mm)	Mass (kg)
2 500	7.9
2 000	6.4
1 500	5.0
1 295	4.4
1 219	4.2
900	3.2
600	2.4

High Tensile Tube 48 mm diameter	
Length (mm)	Mass (kg)
4 000	20.5
3 500	17.9
3 000	14.8
2 500	12.3
2 000	9.8
1 500	7.4
1 000	4.9
500	2.5

BASE JACK

Tube 38mm diameter x 4mm

Thread 610 R/O

Mass 4.3kg

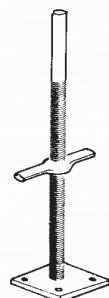

Base Jack

NOTE: Maximum safe shear load on each V-Pressing is 10kN.



CANTILEVER BRACKET

The cantilever bracket is used to extend the slab formwork in areas where there is no support from below. It can be used to support a beam or channel. Typical applications are for slab extensions and access work.



Cantilever Bracket

Length (mm)	Mass (kg)
900	9.8
532	7.3

KWIKSTRIP BEAM

Heavy duty kwikstrip beams are manufactured from 3mm plate. They support the deck panels which can be removed with the beams after three days and placed on an extra set of support in the next area to be concreted.



Coined H/D Kwikstrip Beam

Length (mm)	Mass (kg)	Load kN
2 500	27.5	42
2 000	22.6	42
1 500	15.1	37
1 000	8.9	26
900	7.9	29

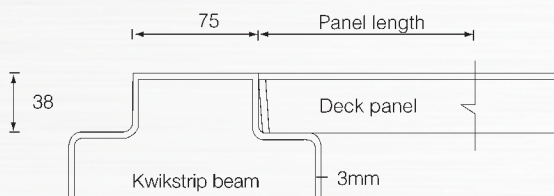

DECK PANEL

The deck panel is manufactured from 2.5 or 3mm plate. The edges are coined to ensure that the panels butt up to each other resulting in a perfect concrete finish on the underneath of the slab.

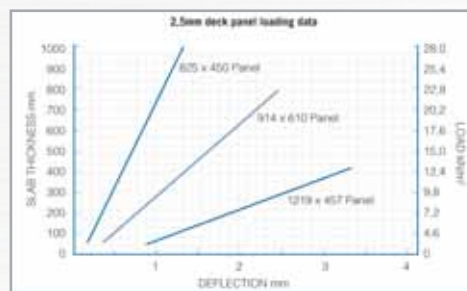
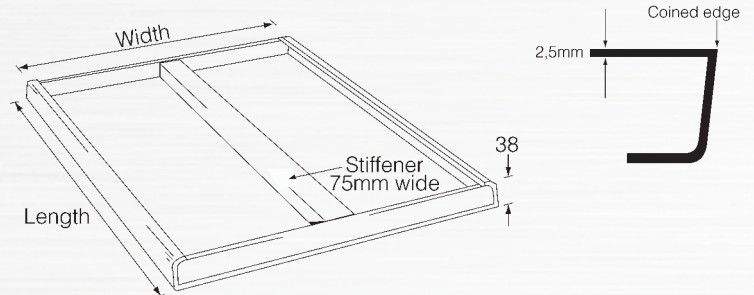

Loadings are based on 2.5mm face plate and a 2.5mm folded channel stiffener.

Coined Deck Panel

Size (mm)	Mass (kg)
1 219 x 457	18.3
1 219 x 305	10.3
1 219 x 229	8.2
1 219 x 152	6.2
914 x 610	17.3
914 x 457	14.1
914 x 305	7.8
914 x 229	6.3
914 x 152	4.7
825 x 450	12.3
825 x 300	7.2
825 x 200	4.4
825 x 100	3.4
1 425 x 450 (double stiffener)	21.7
1 425 x 300	14.5

DECK FILLER

Deck fillers facilitate 'make-up' sections by sliding over the adjacent deck panels.

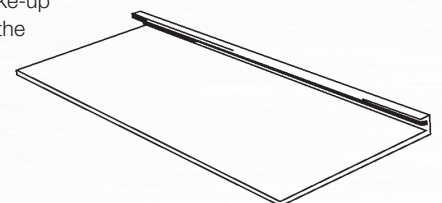



PROPS

HIGH LOAD CAPACITY 20kN AND 30kN PROPS

Props are made of steel tubing. The low weight combined with highload-bearing capacity makes these steel props very cost effective. They are used as support to a propping height of 4000mm. They are available in both galvanised and painted form.

20kN RANGE

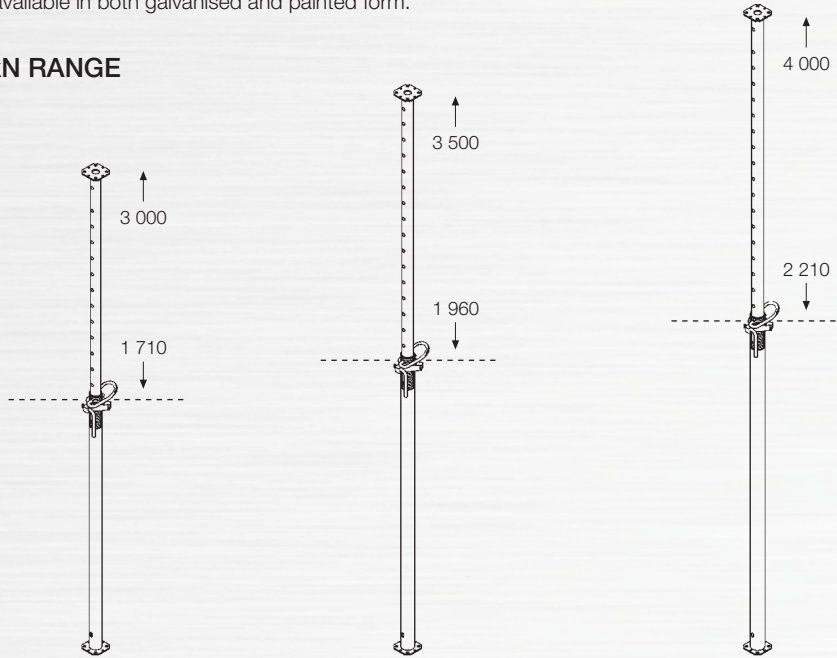

20-300
L = 1 710 - 3 000 (mm)
Weight = 15.9kg

20-350
L = 1 960 - 3 500 (mm)
Weight = 19.4kg

20-400
L = 2 210 - 4 000 (mm)
Weight = 22.8kg

Loading Capacity: 20kN The permissible prop load is 20kN for all extension lengths

30kN RANGE

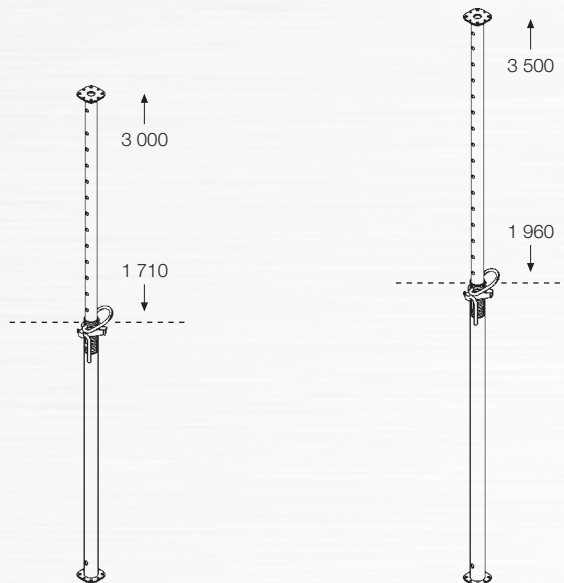

30-300
L = 1 710 - 3 000 (mm)
Weight = 18.9kg

30-350
L = 1 960 - 3 500 (mm)
Weight = 23.0kg

Loading Capacity: 30kN The permissible prop load is 30kN for all extension lengths





STANDARD PROP

The versatile standard prop is available in four sizes which provide a range of propping heights from 1.676m to 4.876m. Props are multi-functional and can be used to back-prop both beams and slabs until the concrete has cured. They are also widely used to support box floor centres on which decking plates are placed to form light slabs suitable for low cost housing developments. The box floor centres are adjustable to cater for different widths between walls. The three sizes of box floor centres allow for a minimum span of 1.219m up to a maximum of 4.724m.

Size	Length (mm)	Mass (kg)
No. 1	1 676 - 3 124	20.1
No. 2	1 981 - 3 352	21.0
No. 3	2 590 - 3 962	23.3
No. 4	3 200 - 4 876	27.4

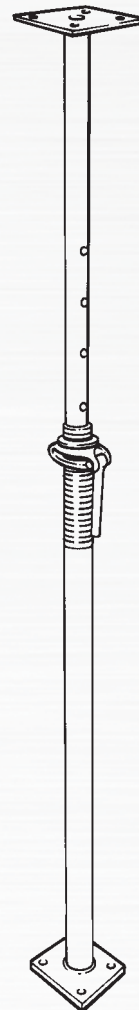

FORK HEAD SPIGOT

Is used to keep the main bearers centrally positioned over the props.



Forkhead spigot

Intermediate spigot





NUMBER: +243 995 355 132
MOBILE: +27 72 178 5406
WATSAPP: +27 72 178 5406



JOHAN.KRIEL@DRS-CD.COM



Suite 302, Zambia National Building
Society, President Avenue, Ndola,
Zambia