

# LIFTING • RIGGING • LASHING • PULLING

# PRODUCT CATALOGUE

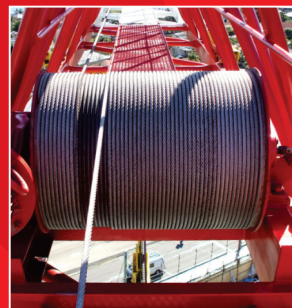



## STEEL WIRE ROPE

Steel wire ropes manufactured to various international standards.

Steel wire ropes are available in a variety of diameters, constructions and finishes. Ropes can be supplied in any length with end fittings as required

### Construction: 6 x 7 FC (Galvanised Steel) From 1.5 - 10mm

#### Product Code

WR01,5/6X7G  
WR02,0/6X7G  
WR02,5/6X7G  
WR03,0/6X7G  
WR04/6X7G  
WR05/6X7G  
WR06,0/6X7G  
WR08/6X7G  
WR10/6X7G

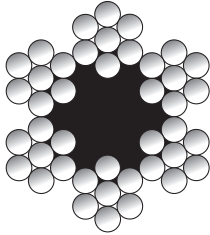

### Construction: 7 x 7 WMC (Galvanised Steel) From 1 - 6mm

#### Product Code

WR01,0/7X7G  
WR01,5/7X7G  
WR02,0/7X7G  
WR02,5/7X7G  
WR03,0/7X7G  
WR03,5/7X7G  
WR04/7X7G  
WR05/7X7G  
WR06,0/7X7G

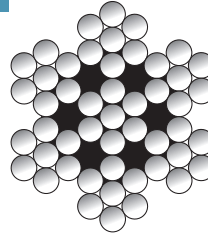

### Construction: 7 x 7 WMC (Stainless Steel Gr316) 1 & 1.5mm

#### Product Code

WR01,0/7X7S  
WR01,5/7X7S  
WR06,0/7X7S

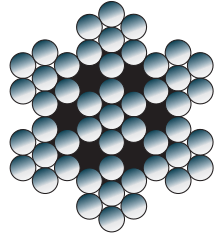

### Construction: 7 x 7 WMC (Stainless Steel Gr304) 1 - 5mm

#### Product Code

WR01,0/7X7SS  
WR01,5/7X7SS  
WR02,0/7X7SS  
WR02,5/7X7SS  
WR03,0/7X7SS  
WR04/7X7SS  
WR05/7X7SS

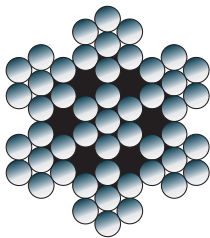

### Construction: 6 x 19 FC (Galvanised Steel) From 3.0 - 22mm

#### Product Code

WR03,0/6X19G  
WR04/6X19G  
WR05/6X19G  
WR06,0/6X19G  
WR08/6X19G  
WR10/6X19G  
WR13/6X19G (9/9/1)  
WR16/6X19G (9/9/1)  
WR19/6X19G (9/9/1)  
WR22/6X19G (9/9/1)

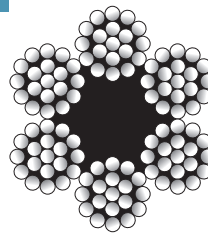

### Construction: 6 x 19 IWRC (Galvanised Steel) From 8.0 - 16mm

#### Product Code

WR08/6X19GIWRC  
WR10/6X19GIWRC  
WR11/6X19GIWRC  
WR13/6X19GIWRC  
WR16/6X19GIWRC  
WR20/6X19GIWRC  
  
Ungalvanised 8.0 & 16  
WR08/6X19BIWRC  
WR16/6X19BIWRC

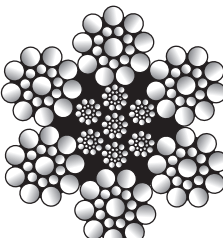

### Construction: 6 x 36 FC (Galvanised Steel) From 6 - 38mm

#### Product Code

WR06,0/6X36G WR18/6X36G  
WR08/6X36G WR19/6X36G  
WR09,0/6X36G WR20/6X36G  
WR10/6X36G WR22/6X36G  
WR11/6X36G WR24/6X36G  
WR12/6X36G WR26/6X36G  
WR13/6X36G WR28/6X36G  
WR14/6X36G WR32/6X36G  
WR16/6X36G WR38/6X36G

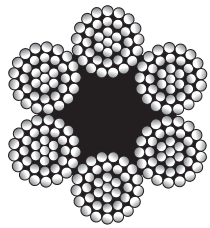

### Construction: 6 x 36 FC (Ungalvanised Steel) From 6 - 56mm

#### Product Code

WR06,0/6X36B WR20/6X36B  
WR08/6X36B WR22/6X36B  
WR09,0/6X36B WR24/6X36B  
WR10/6X36B WR26/6X36B  
WR11/6X36B WR28/6X36B  
WR12/6X36B WR32/6X36B  
WR13/6X36B WR36/6X36B  
WR14/6X36B WR38/6X36B  
WR16/6X36B WR44/6X36B  
WR18/6X36B WR50/6X36B  
WR19/6X36B WR56/6X36B

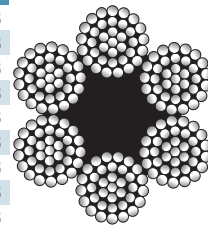

### Construction: 6 x 36 IWRC (Galvanised Steel) From 6 - 56mm

#### Product Code

WR06,0/6X36GIWRC WR20/6X36GIWRC  
WR08/6X36GIWRC WR22/6X36GIWRC  
WR09,0/6X36GIWRC WR24/6X36GIWRC  
WR10/6X36GIWRC WR26/6X36GIWRC  
WR11/6X36GIWRC WR28/6X36GIWRC  
WR12/6X36GIWRC WR32/6X36GIWRC  
WR13/6X36GIWRC WR36/6X36GIWRC  
WR14/6X36GIWRC WR38/6X36GIWRC  
WR16/6X36GIWRC WR44/6X36GIWRC  
WR18/6X36GIWRC WR50/6X36GIWRC  
WR19/6X36GIWRC WR56/6X36GIWRC

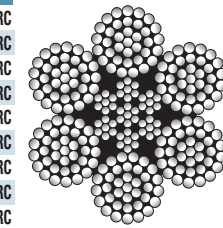

### Construction: 6 x 36 IWRC (Ungalvanised Steel) From 6 - 38mm

#### Product Code

WR06,0/6X36BIWRC WR18/6X36BIWRC  
WR08/6X36BIWRC WR19/6X36BIWRC  
WR09,0/6X36BIWRC WR20/6X36BIWRC  
WR10/6X36BIWRC WR22/6X36BIWRC  
WR11/6X36BIWRC WR24/6X36BIWRC  
WR12/6X36BIWRC WR26/6X36BIWRC  
WR13/6X36BIWRC WR28/6X36BIWRC  
WR14/6X36BIWRC WR32/6X36BIWRC  
WR16/6X36BIWRC WR38/6X36BIWRC

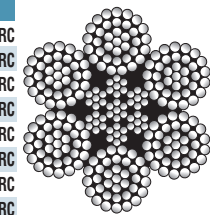

### Construction: 6 x 36 IWRC (Ungalvanised Steel) Compacted From 22mm - 28mm

#### Product Code

WR22/6X36BCIWRC  
WR24/6X36BCIWRC  
WR26/6X36BCIWRC  
WR28/6X36BCIWRC

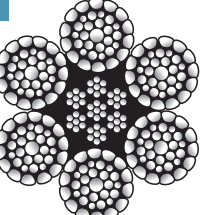

### Construction: 19 x 7 WMC (Ungalvanised Steel) From 9 - 28mm

#### Product Code

WR06,0/19X7BWMC WR16/19X7BWMC  
WR08/19X7BWMC WR17/19X7BWMC  
WR09,0/19X7B WMC WR18/19X7BWMC  
WR09,5/19X7B WMC WR19/19X7BWMC  
WR10/19X7BWMC WR20/19X7BWMC  
WR11/19X7BWMC WR22/19X7BWMC  
WR12/19X7BWMC WR24/19X7BWMC  
WR13/19X7BWMC WR26/19X7BWMC  
WR14/19X7BWMC WR28/19X7BWMC  
WR15/19X7BWMC

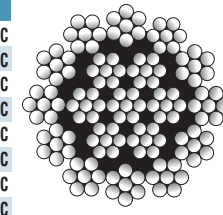

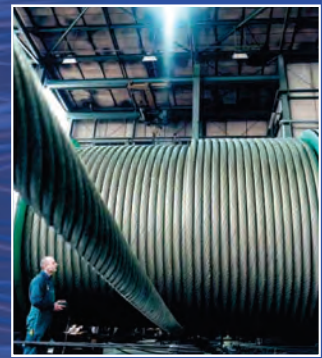

## STEEL WIRE ROPE

Steel wire ropes manufactured to various international standards.

Steel wire ropes are available in a variety of diameters, constructions and finishes. Ropes can be supplied in any length with end fittings as required

**Construction: 7 x 19 WMC (Galvanised Steel)**  
3.5 & 4mm

**Product Code**  
WR03,5/7X19G  
WR04/7X19G

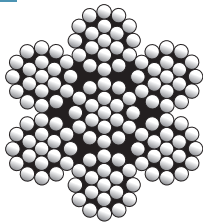

**Construction: 7 x 19 WMC (Stainless Steel Gr304 & 316) Gr 316** from 2 - 19mm

**Product Code**  
WR02,0/7X19S WR08/7X19S  
WR02,5/7X19S WR10/7X19S  
WR03,0/7X19S WR13/7X19S  
WR04/7X19S WR16/7X19S  
WR05/7X19S WR19/7X19S  
WR06,0/7X19S

Gr 304 from 6 - 19mm  
WR06,0/7X19SS WR13/7X19SS  
WR08/7X19SS WR16/7X19SS  
WR10/7X19SS WR19/7X19SS

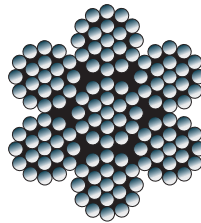

**Construction: 1 x 19 WMC (Galvanised Steel)**  
From 1 - 6mm

**Product Code**  
WR01,0/1X19G WR02,8/1X19G  
WR01,2/1X19G WR03,0/1X19G  
WR01,25/1X19G WR03,5/1X19G  
WR01,5/1X19G WR04/1X19G  
WR02,0/1X19G WR06,0/1X19G  
WR02,5/1X19G

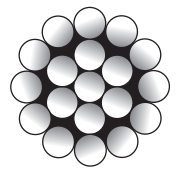

**Construction: 1 x 19 WMC (Stainless Steel Gr316)** From 1 - 6mm

**Product Code**  
WR01,0/1X19S  
WR01,5/1X19S  
WR02,0/1X19S  
WR02,5/1X19S  
WR03,0/1X19S  
WR03,5/1X19S  
WR04/1X19S  
WR06,0/1X19S  
WR08/1X19S

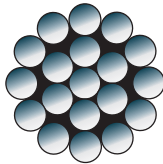

**Construction: 8 x 19 Compacted (Ungalvanised Steel) RHRL** from 6.5 - 11mm

**Product Code**  
WR06,5/8X19BCIWRC  
WR07,5/8X19BCIWRC  
WR08/8X19BCIWRC  
WR09,0/8X19BCIWRC  
WR11/8X19BCIWRC

LHRL  
from 8 - 11mm  
WR08/8X19BCIWRCLHO  
WR09,0/8X19BCIWRCLHO  
WR11/8X19BCIWRCLHO

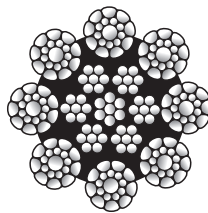

**Construction: 8 x 26 Compacted (Ungalvanised Steel)** From 13 - 20mm

**Product Code**  
WR12/8X26BCIWRC  
WR13/8X26BCIWRC  
WR14/8X26BCIWRC  
WR16/8X26BCIWRC  
WR18/8X26BCIWRC  
WR19/8X26BCIWRC  
WR20/8X26BCIWRC  
WR22/8X26BCIWRC  
WR24/8X26BCIWRC  
WR26/8X26BCIWRC  
WR32/8X26BCIWRC

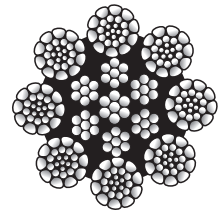

LHRL  
13 & 14mm  
WR13/8X26BCIWRCLHO  
WR14/8X26BCIWRCLHO

**Construction: 35 x 7 WMC Compacted (Ungalvanised Steel)** From 10 - 22mm

**Product Code**  
WR10/35X7BC WR19/35X7BC  
WR11/35X7BC WR20/35X7BC  
WR12/35X7BC WR21/35X7BC  
WR13/35X7BC WR22/35X7BC  
WR14/35X7BC WR23/35X7BC  
WR15/35X7BC WR24/35X7BC  
WR16/35X7BC WR25/35X7BC  
WR17/35X7BC WR26/35X7BC  
WR18/35X7BC

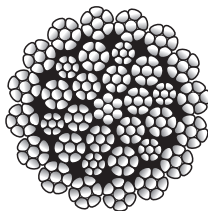

LHL  
WR16/35X7BCLHL WR18/35X7BCLHL  
WR17/35X7BCLHL WR21/35X7BCLHL

**Construction: PVC Clear Covered (Galvanised Steel)**  
2-3mm; 2.5-5mm; 3-5mm; 4-6mm; 6-8mm; 8-10mm

**Product Code**  
WR02,0/PVC3  
WR02,5/PVC5  
WR03,0/PVC5  
WR04/PVC6  
WR06,0/PVC8  
WR08/PVC10

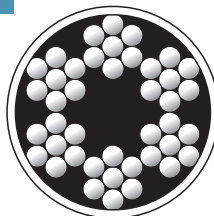

**Construction: 8 x 19 FC (Ungalvanised Steel) Elevator Rope** From 8 - 16mm

**Product Code**  
WRE08/8x19B  
WRE10/8x19B  
WRE12/8x19B  
WRE13/8x19B  
WRE16/8x19B

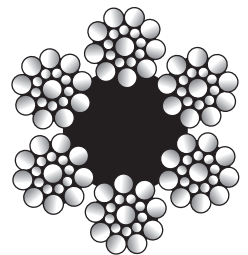

**Construction: PVC Transparent Colour Covered (Galvanised Steel)**

2-3mm; 3-5mm; 4-6mm; 6-8mm; 8-10mm

**Product Code**  
WR02,0/PVC3Y  
WR03,0/PVC5R  
WR04/PVC6B  
WR06,0/PVC8G  
WR08/PVC10O  
WR10/PVC12B

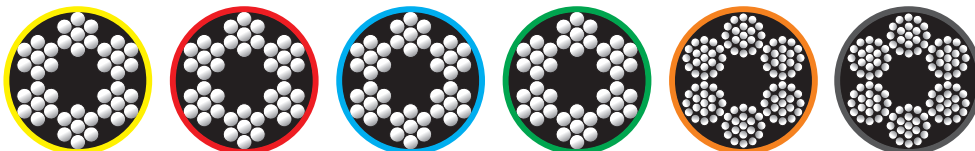

# VITALIFT®



## STEEL WIRE ROPE SLINGS

Bespoke steel wire rope slings manufactured to suit your requirements.

- Manufactured to international specifications
- Afgrip slings manufactured with seamless extruded ferrules from Germany
- Can be proof loaded individually at additional cost
- 6:1 Safety factor as required by the Occupational Health and Safety Act
- Stainless steel slings also produced to customer requirements
- DNV certified slings available on request

### How to order a VITALIFT steel wire rope sling (Please Specify):

- Type of sling required (one leg, two legs, etc)
- WLL limit required (See chart overleaf for standard slings).
- Type of splice:
  - Afgrip (also know as Turn-Back, or Aluminium)
  - Superloop (also know as Flemish, National, or Jupiter)
- Effective length (leg length / pull to pull length / circumference)
- Finish of steel wire rope required:
  - Ungalvanised, galvanised or stainless steel
  - Whether eyes are soft (standard) or should have thimbles (hard)
  - Eye sizes for soft eyes (see standard eye sizes on chart overleaf)
  - Serial numbers required
  - Any fittings required

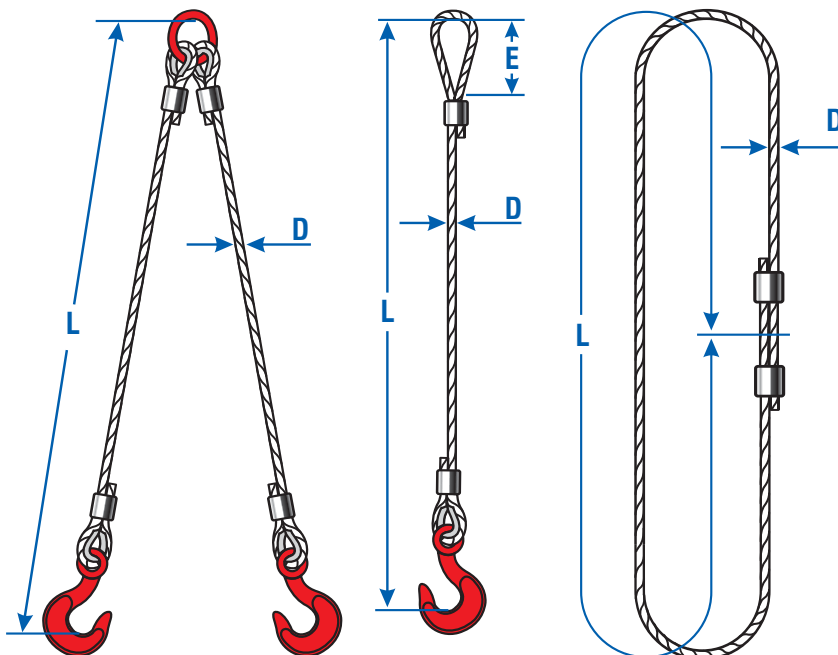
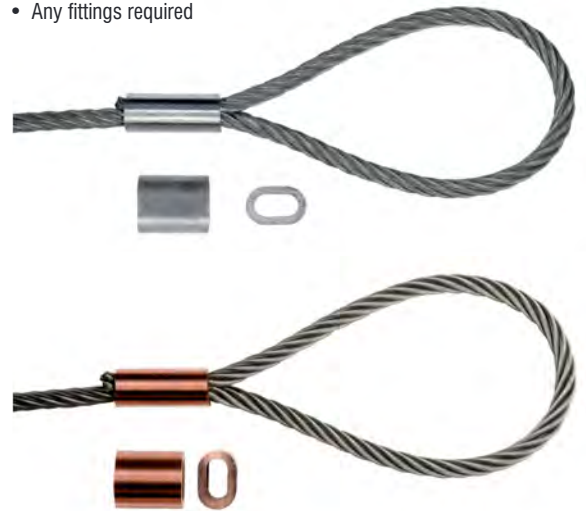
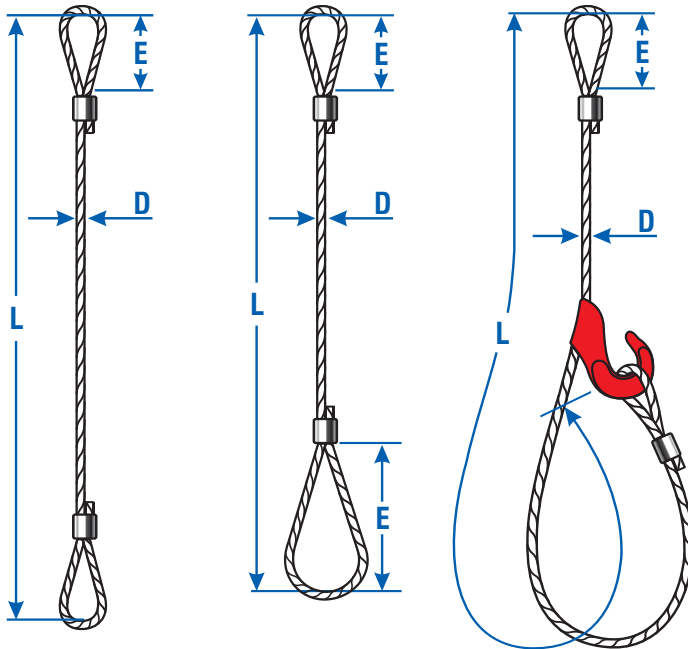



# STEEL WIRE ROPE SLINGS

Bespoke steel wire rope slings manufactured to suit your requirements.

Working load limits in kg for 6X36 Afgrip steel wire rope slings

## Fibre Core (FC)

Rope Ø (mm)	Std. Soft Eye Size (mm)	Single Leg at 0°	Double Leg at 60°	Double Leg at 90°	Triple (45°) & Quadruple Leg at 90°
6	100	300	510	420	630
8	100	600	1020	840	1260
9	150	800	1300	1100	1600
10	150	1000	1700	1400	2100
11	150	1200	2000	1600	2500
12	200	1400	2300	1900	2900
13	200	1700	2800	2300	3500
14	250	2000	3400	2800	4200
16	250	2500	4200	3500	5200
18	300	3200	5400	4400	6700
19	350	3600	6100	5000	7500
20	350	4000	6800	5600	8400
22	350	4800	8100	6700	10000
24	400	5700	9600	7900	11900
26	400	6700	11300	9300	14000
28	450	7800	13200	10900	16300
32	600	10100	17100	14100	21200
36	750	12900	21900	18000	27000
38	750	14400	24400	20100	30200
44	900	19200	32600	26800	40300
50	1000	24800	42100	34700	52000
56	1200	31100	52800	43500	65300

## Independent Wire Rope Core (IWRC)

Rope Ø (mm)	Std. Soft Eye Size (mm)	Single Leg at 0°	Double Leg at 60°	Double Leg at 90°	Triple (45°) & Quadruple Leg at 90°
6	100	350	595	490	735
8	100	700	1190	980	1470
9	150	800	1300	1100	1600
10	150	1100	1800	1500	2300
11	150	1300	2200	1800	2700
12	200	1500	2500	2100	3100
13	200	1800	3000	2500	3700
14	250	2100	3500	2900	4400
16	250	2800	4700	3900	5800
18	300	3500	5900	4900	7300
19	350	3900	6600	5400	8100
20	350	4300	7300	6000	9000
22	350	5200	8800	7200	10900
24	400	6200	10500	8600	13000
26	400	7200	12200	10000	15100
28	450	8400	14200	11700	17600
32	600	11000	18700	15400	23100
36	750	13900	23600	19400	29100
38	750	15500	26300	21700	32500
44	900	20700	35100	28900	43400
50	1000	26800	45500	37500	56200
56	1200	33500	56900	46900	70300

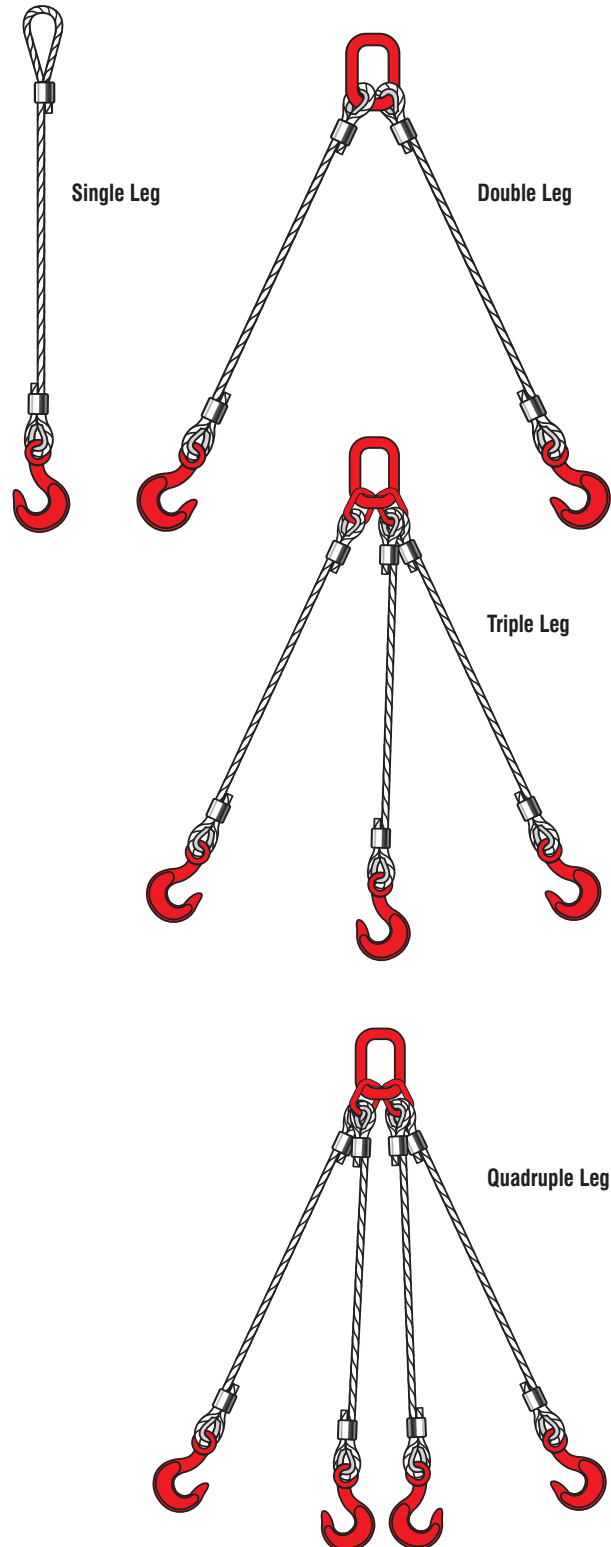



# GRADE 80 & 100 CHAIN SLINGS

Chain slings are the classic and widely used load handling attachment for a wide variety of lifting applications. They feature flexibility and extremely high durability.

We offer complete chain slings and components in grades 80 & 100 as well as corresponding accessories and spare parts. Chain slings made to order according to your requirements.

All lifting components are uniformly marked with equivalent chain size and grade. Safety factor: 4:1

## 1 LEG SLING

(Grade 80 Shown)



## 2 LEG SLING

(Grade 100 Shown)

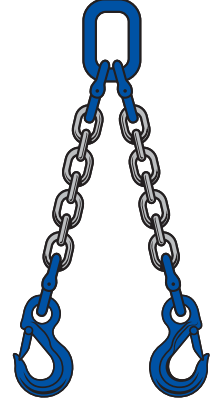

### WORKING LOAD LIMITS

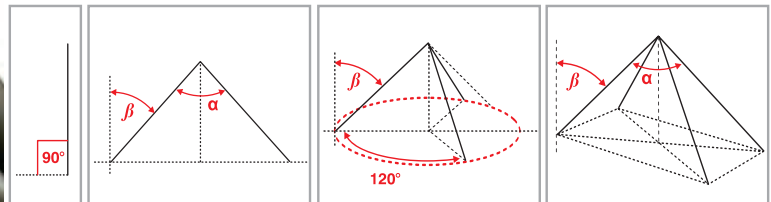

Chain Dia. (mm)	Grade	One Leg		Two Leg			Three Leg			Four Leg		
		t	t	t	t	t	t	t	t	t	t	t
7	80	1.50	2.55	2.10	1.50	3.90	3.15	2.25	3.90	3.15	2.25	
8	100	2.50	4.25	3.50	2.50	6.50	5.25	3.75	6.50	5.25	3.75	
10	80	3.15	5.35	4.41	3.15	8.19	6.62	4.72	8.19	6.62	4.72	
10	100	4.00	6.80	5.60	4.00	10.40	8.40	6.00	10.40	8.40	6.00	
13	80	5.30	9.00	7.42	5.30	13.78	11.13	7.95	13.78	11.13	7.95	
13	100	6.70	11.39	9.38	6.70	17.42	14.07	10.05	17.42	14.07	10.05	
16	80	8.00	13.60	11.20	8.00	20.80	16.80	12.00	20.80	16.80	12.00	
16	100	10.00	17.00	14.00	10.00	26.00	21.00	15.00	26.00	21.00	15.00	
20	80	12.50	21.25	17.50	12.50	32.50	26.25	18.75	32.50	26.25	18.75	
22	80	15.00	25.50	21.00	15.00	39.00	31.50	22.50	39.00	31.50	22.50	
26	80	20.40	34.68	28.56	20.40	53.00	42.84	30.60	53.00	42.84	30.60	
32	80	31.50	53.55	44.10	31.50	81.90	66.15	47.25	81.90	66.15	47.25	
<b>Factor</b>		1.0	1.7	1.4	1.0	2.6	2.1	1.5	2.6	2.1	1.5	

## 3 LEG SLING

(Grade 80 Shown)



## 4 LEG SLING

(Grade 100 Shown)





# GRADE 80 & 100 CHAIN SLINGS

Chain slings are the classic and widely used load handling attachment for a wide variety of lifting applications. They feature flexibility and extremely high durability.

We offer complete chain slings and components in grades 80 & 100 as well as corresponding accessories and spare parts. Chain slings made to order according to your requirements.

All lifting components are uniformly marked with equivalent chain size and grade. Safety factor: 4:1

## 1 LEG SLING

(Grade 80 Shown)



## 2 LEG SLING

(Grade 100 Shown)

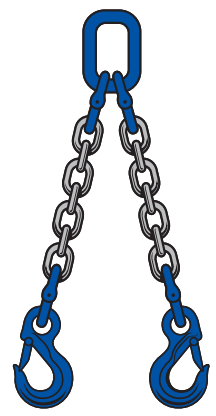

### WORKING LOAD LIMITS

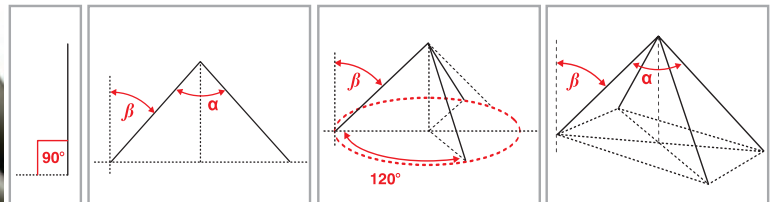

Chain Dia. (mm)	Grade	Two Leg				Three Leg			Four Leg		
		t	t	t	t	t	t	t	t	t	t
7	80	1.50	2.55	2.10	1.50	3.90	3.15	2.25	3.90	3.15	2.25
8	100	2.50	4.25	3.50	2.50	6.50	5.25	3.75	6.50	5.25	3.75
10	80	3.15	5.35	4.41	3.15	8.19	6.62	4.72	8.19	6.62	4.72
10	100	4.00	6.80	5.60	4.00	10.40	8.40	6.00	10.40	8.40	6.00
13	80	5.30	9.00	7.42	5.30	13.78	11.13	7.95	13.78	11.13	7.95
13	100	6.70	11.39	9.38	6.70	17.42	14.07	10.05	17.42	14.07	10.05
16	80	8.00	13.60	11.20	8.00	20.80	16.80	12.00	20.80	16.80	12.00
16	100	10.00	17.00	14.00	10.00	26.00	21.00	15.00	26.00	21.00	15.00
20	80	12.50	21.25	17.50	12.50	32.50	26.25	18.75	32.50	26.25	18.75
22	80	15.00	25.50	21.00	15.00	39.00	31.50	22.50	39.00	31.50	22.50
26	80	20.40	34.68	28.56	20.40	53.00	42.84	30.60	53.00	42.84	30.60
32	80	31.50	53.55	44.10	31.50	81.90	66.15	47.25	81.90	66.15	47.25
<b>Factor</b>		1.0	1.7	1.4	1.0	2.6	2.1	1.5	2.6	2.1	1.5

## 3 LEG SLING

(Grade 80 Shown)



## 4 LEG SLING

(Grade 100 Shown)





## GRADE 80 & 100 CHAIN SLINGS

Chain slings are the classic and widely used load handling attachment for a wide variety of lifting applications. They feature flexibility and extremely high durability.

### STANDARD SLINGS

#### 1 LEG SLING

(Grade 80 Shown)



#### 2 LEG SLING

(Grade 100 Shown)

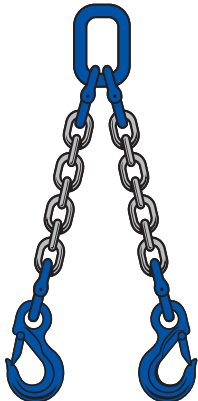

#### 3 LEG SLING

(Grade 80 Shown)



#### 4 LEG SLING

(Grade 100 Shown)



### OTHER SLING EXAMPLES

#### CHOKER SLING

(Grade 100 Shown)

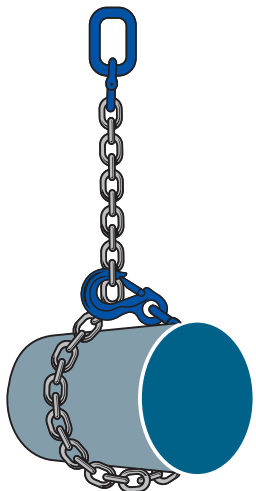

#### ENDLESS SLING

(Grade 80 Shown)

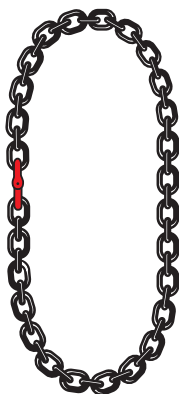

#### SINGLE ADJUSTABLE LOOP CHAIN SLING

(Grade 100 Shown)



#### SINGLE BASKET SLING

(Grade 80 Shown)



#### DOUBLE BASKET SLING

(Grade 100 Shown)





# GRADE 80 CHAIN SLINGS

Chain slings are the classic and widely used load handling attachment for a wide variety of lifting applications. They feature flexibility and extremely high durability.

Premium quality chain slings assembled with chain made to EN818-2.

We offer complete chain slings and components as well as corresponding accessories and spare parts.

Chain slings made to order according to your requirements.

All lifting components are uniformly marked with equivalent chain size and grade.

Safety factor: 4:1

1 LEG SLING

2 LEG SLING



3 LEG SLING



4 LEG SLING



## WORKING LOAD LIMITS

	One Leg		Two Leg			Three Leg			Four Leg		
	0°	30°	45°	60°	30°	45°	60°	30°	45°	60°	
Angle from vertical - $\beta$	0°	30°	45°	60°	30°	45°	60°	30°	45°	60°	
Angle between legs - $\alpha$	-	60°	90°	120°	-	-	-	60°	90°	120°	
Chain Dia. (mm)	t	t	t	t	t	t	t	t	t	t	
7	1.50	2.55	2.10	1.50	3.90	3.15	2.25	3.90	3.15	2.25	
10	3.15	5.35	4.41	3.15	8.19	6.62	4.72	8.19	6.62	4.72	
13	5.30	9.00	7.42	5.30	13.78	11.13	7.95	13.78	11.13	7.95	
16	8.00	13.60	11.20	8.00	20.80	16.80	12.00	20.80	16.80	12.00	
20	12.50	21.25	17.50	12.50	32.50	26.25	18.75	32.50	26.25	18.75	
22	15.00	25.50	21.00	15.00	39.00	31.50	22.50	39.00	31.50	22.50	
26	20.40	34.68	28.56	20.40	53.00	42.84	30.60	53.00	42.84	30.60	
32	31.50	53.55	44.10	31.50	81.90	66.15	47.25	81.90	66.15	47.25	
Factor	1.0	1.7	1.4	1.0	2.6	2.1	1.5	2.6	2.1	1.5	

Check the Working Load Limit before using alloy slings at temperatures exceeding 200°C



# GRADE 100 CHAIN SLINGS

Chain slings are the classic and widely used load handling attachment for a wide variety of lifting applications. They feature flexibility and extremely high durability.

We offer complete chain slings and components as well as corresponding accessories and spare parts. Chain slings made to order according to your requirements. All lifting components are uniformly marked with equivalent chain size and grade.

Safety factor: 4:1  
**25% stronger than the corresponding diameter Grade 80 chain.**

1 LEG SLING

2 LEG SLING



3 LEG SLING



4 LEG SLING



## WORKING LOAD LIMITS

Chain Dia. (mm)	Grade	Two Leg				Three Leg			Four Leg		
		t	t	t	t	t	t	t	t	t	t
8	2.50	4.25	3.50	2.50	6.50	5.25	3.75	6.50	5.25	3.75	
10	4.00	6.80	5.60	4.00	10.40	8.40	6.00	10.40	8.40	6.00	
13	6.70	11.39	9.38	6.70	17.42	14.07	10.05	17.42	14.07	10.05	
16	10.00	17.00	14.00	10.00	26.00	21.00	15.00	26.00	21.00	15.00	
<b>Factor</b>	<b>1.0</b>	<b>1.7</b>	<b>1.4</b>	<b>1.0</b>	<b>2.6</b>	<b>2.1</b>	<b>1.5</b>	<b>2.6</b>	<b>2.1</b>	<b>1.5</b>	

Check the Working Load Limit before using alloy slings at temperatures exceeding 200°C

# ILULA®



## GRADE 80 CHAIN SLINGS



Chain slings are the classic and widely used load handling attachment for a wide variety of lifting applications. They feature flexibility and extremely high durability.

### NEW PRODUCT TO OUR RANGE

We offer complete chain slings and components as well as corresponding accessories and spare parts. Chain slings made to order according to your requirements.

All lifting components are uniformly marked with equivalent chain size and grade. Safety factor: 4:1

#### WORKING LOAD LIMITS

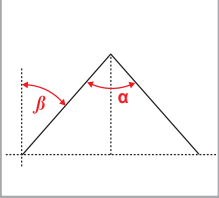
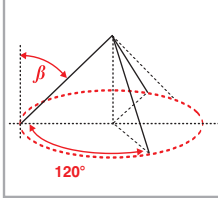
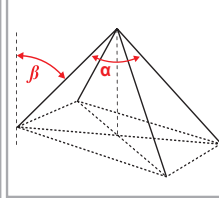





	One Leg	Two Leg			Three Leg			Four Leg		
Angle from vertical - $\beta$	0°	30°	45°	60°	30°	45°	60°	30°	45°	60°
Angle between legs - $\alpha$	-	60°	90°	120°	-	-	-	60°	90°	120°
Chain Dia. (mm)	t	t	t	t	t	t	t	t	t	t
7	1.50	2.55	2.10	1.50	3.90	3.15	2.25	3.90	3.15	2.25
10	3.15	5.35	4.41	3.15	8.19	6.62	4.72	8.19	6.62	4.72
13	5.30	9.00	7.42	5.30	13.78	11.13	7.95	13.78	11.13	7.95
16	8.00	13.60	11.20	8.00	20.80	16.80	12.00	20.80	16.80	12.00
20	12.50	21.25	17.50	12.50	32.50	26.25	18.75	32.50	26.25	18.75
Factor	1.0	1.7	1.4	1.0	2.6	2.1	1.5	2.6	2.1	1.5

1 LEG SLING

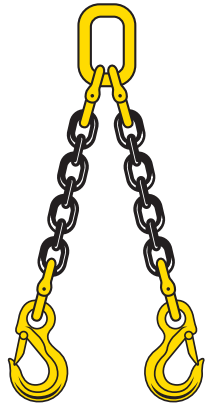

2 LEG SLING



3 LEG SLING



4 LEG SLING





## WEBBING SLINGS

Versatile and lightweight multiple leg webbing slings now available with quicker delivery.

### NEW PRODUCT TO OUR RANGE

Webbing slings with special Grade 80 components ideal for applications where damage to the item being lifted needs to be minimised. Easier handling

compared to chain slings. Webbing connectors enable easy attachment of webbing slings to master links, eye sling hooks or eye self-locking hooks.

#### WORKING LOAD LIMITS



	Two Leg			Three Leg			Four Leg			
Angle from vertical - $\beta$	0°	30°	45°	60°	30°	45°	60°	30°	45°	60°
Angle between legs - $\alpha$	-	60°	90°	120°	-	-	-	60°	90°	120°
Webbing Sling Capacity (Ton)	t	t	t	t	t	t	t	t	t	t
1	1	1.7	1.4	1.0	2.6	2.1	1.5	2.6	2.1	1.5
2	2	3.4	2.8	2.0	5.2	4.2	3.0	5.2	4.2	3.0
3	3	5.1	4.2	3.0	7.8	6.3	4.5	7.8	6.3	4.5
4	4	6.8	5.6	4.0	10.4	8.4	6.3	10.4	8.4	6.0
Factor	1.0	1.7	1.4	1.0	2.6	2.1	1.5	2.6	2.1	1.5

#### 1 LEG SLING

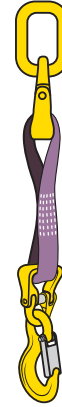

#### 2 LEG SLING

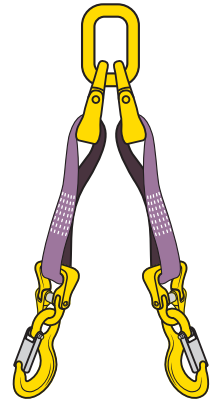

#### 3 LEG SLING

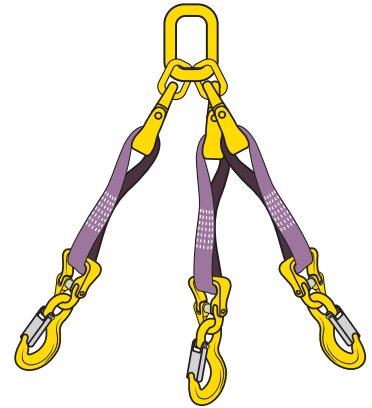

#### 4 LEG SLING

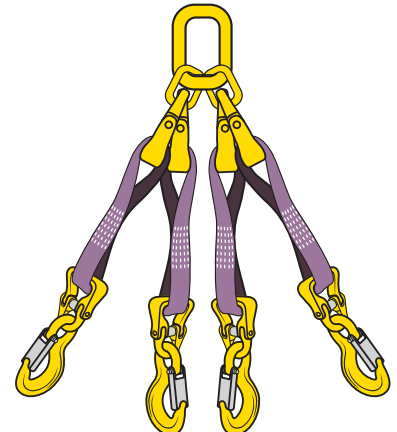

#### IEWJ SLING JOINER

Grade 80 Sling Joiner to connect two webbing slings or to make webbing slings endless.

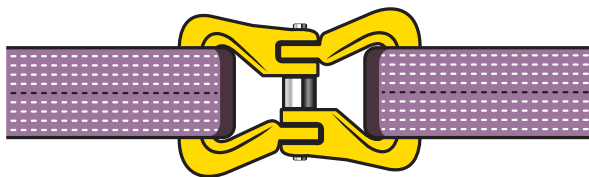



**VITALIFT®**



# DUPLEX FLAT WEBBING AND ENDLESS ROUND SLINGS

Manufactured to EN1492 and SANS94

- Slings colour coded to WLL for easy identification
- All slings are manufactured to comply with:  
EN1491-1 and SANS94-1 Flat woven webbing slings  
EN1491-2 and SANS94-2 Roundslings
- Safety factor 7:1 in compliance with standards and the Occupational Health and Safety Act
- Each sling serial numbered for traceability
- Common sizes available ex-stock, larger capacity slings can be manufactured to order



## WORKING LOAD LIMITS & COLOUR CODES

Colour Coding t	Straight / Vertical Lift t	Choked Lift t	Basket Hitch		
			Parallel t	0° to 90° between legs t	90° to 120° between legs t
Violet	1.0	0.8	2.0	1.4	1.0
Green	2.0	1.6	4.0	2.8	2.0
Yellow	3.0	2.4	6.0	4.2	3.0
Grey	4.0	3.2	8.0	5.6	4.0
Red	5.0	4.0	10.0	7.0	5.0
Brown	6.0	4.8	12.0	8.4	6.0
Blue	8.0	6.4	16.0	11.2	8.0
Orange	10.0	8.0	20.0	14.0	10.0
Factor	1.0	0.8	2.0	1.4	1.0

Slings with higher working load limits available on request

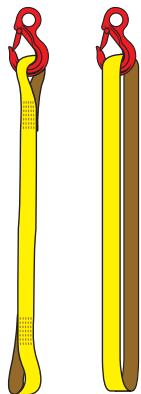

VERTICAL SLING

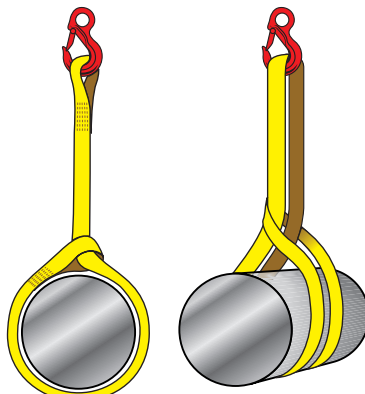

CHOKER SLING

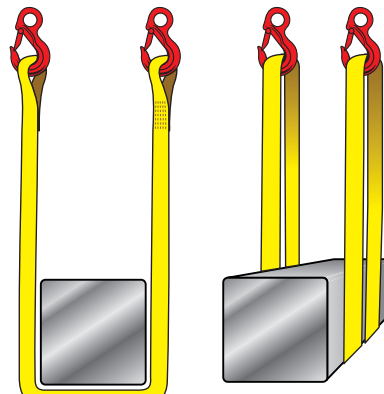

PARALLEL BASKET SLING

Due to our policy of continual product development, dimensions, weights and specifications may change without prior notice. Please check with your sales representative when ordering.



# ELECTRIC HOISTS

Robust, Durable and Reliable Technology



## BUILDER'S HOIST

*SUPER COMPACT, SUPER LIGHT, HIGH SPEED, HIGH PERFORMANCE*

- Compact & lightweight design
- Easily mounted
- Limit lever switch prevents over-winding
- Double brake system
- Plug-in connections for maximum portability
- Complete with 360° universal joint saddle hook

<b>CAPACITY</b>	250 Kg
<b>SPEED</b>	15m/min
<b>OUTPUT</b>	1.3 kW
<b>VOLTAGE</b>	220V Single Phase
<b>ROPE</b>	5mm, 6 x 19 FC Galv.
<b>MAX. LIFT</b>	60m
<b>DUTY CYCLE</b>	30%
<b>HEADROOM</b>	700mm
<b>NET WEIGHT</b>	20 Kg



Model Number  
**DU-250A**

## MINI ELECTRIC CHAIN HOISTS

*SUPER COMPACT, SUPER LIGHT, HIGH PERFORMANCE*

- Double brake system
- Over-roll prevention device
- Overload limit device
- Lightweight, modular design with fewer parts for easy maintenance
- Weather and dust protection
- One-piece casting of load frame
- Frame has baked finish for superior resistance to harmful environments

Model Number  
**DU-901**



Model Number  
**DU-902**

MODEL No.	DU-901	DU-902
<b>CAPACITY</b>	500 Kg	1000 Kg
<b>SPEED</b>	5m/min	2.5m/min
<b>OUTPUT</b>	1.2 kW	1.2 kW
<b>VOLTAGE</b>	220V Single Phase	220V Single Phase
<b>CHAIN</b>	6.3 x 19mm	6.3 x 19mm
<b>NO. OF FALLS</b>	1	2
<b>DUTY CYCLE</b>	30%	30%
<b>HEADROOM</b>	500mm	500mm
<b>NET WEIGHT</b>	23 Kg	30 Kg



# MAXIHOIST®

## ELECTRIC CHAIN HOIST & MOTORISED TROLLEY

Electric Chain Hoist 1 Ton, 2 Ton, 3 Ton & 5 Ton Single Speed

- Hoist Body: Manufactured from lightweight aluminium which is rigid allowing for use in extreme working conditions. The design of the cooling fins offers rapid heat dissipation to prevent overheating
- Phase protection relay: Unit will not operate if phases are incorrectly connected
- Limit switch: Durable limit switch device is installed to make the motor stop automatically when safety limits are exceeded
- Side magnetic braking device: The braking device will instantly brake in the case of a power failure or interruption
- Chain bag: The bags are lightweight and durable
- Chain: The chain is imported case hardened grade 80 steel alloy chain
- Pendant control: 48V pendant control for operator safety. The push button is light and durable with an emergency mains cut out
- Hook: Button hook rotates 360 degrees and is fitted with a safety latch



MEU020S380  
2 Ton Hoist

MET010S380  
1 Ton Trolley





**MAXIHOIST®**

# ELECTRIC CHAIN HOIST & MOTORISED TROLLEY

Electric Chain Hoist 1 Ton, 2 Ton, 3 Ton & 5 Ton Single Speed

## HOIST SPECIFICATIONS & DIMENSIONS

Type	Capacity (Ton)	Lifting Height (cm)	Lifting Speed (m/min)	Chain Falls	Power (kW)	Rotation Speed	Phases	Voltage (V)	Frequency
MEU010S380	1	3/9	6.6	1	1.5	1440	3	380	50
MEU020S380	2	3/9	6.6	1	3.0	1440	3	380	50
MEU020S380/2F	2	3/9	3.4	2	1.5	1440	3	380	50
MEU030S380	3	3/9	5.4	1	3.0	1440	3	380	50
MEU050S380	5	3/9	2.6	2	3.0	1440	3	380	50

Type	Capacity (Ton)	Dimension in (mm)											Chain
		H	A	B	D	E	I	J	K	L	M	N	
MEU010S380	1	650	520	260	300	176	Ø42	32	Ø42	32	24	24	7.1 x 21
MEU020S380	2	800	615	295	430	265	Ø49	40	Ø49	40	30	30	10 x 30
MEU020S380/2F	2	750	520	260	300	230	Ø49	35	Ø49	35	30	30	7.1 x 21
MEU030S380	3	845	615	295	430	265	Ø59	48	Ø59	48	35	35	11.2 x 34
MEU050S380	5	1015	620	310	430	325	Ø60	45	Ø60	45	43	43	11.2 x 34

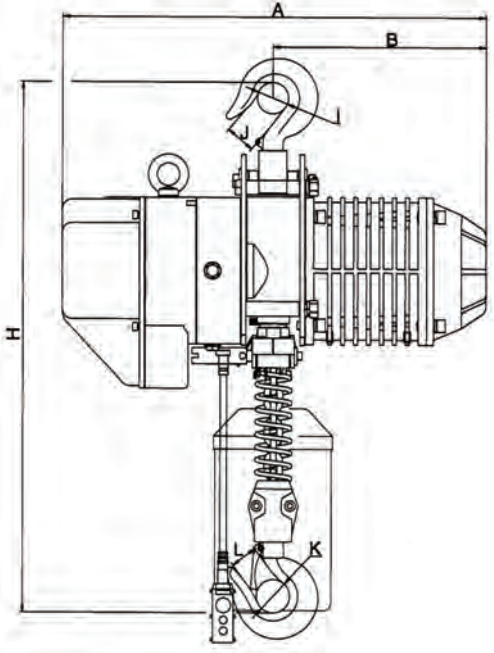

## ELECTRIC TROLLEY SPECIFICATIONS & DIMENSIONS

Type	Capacity (Ton)	Dimension in (mm)				Speed 50Hz (m/min)	Motor (kW)	Min Radius of Turn	I-Beam (mm)
		A	B	R	T				
MET010S380	1	315	212	142	231	10	0,4	0,8	80-160
MET020S380	2	325	220	142	231	10	0,4	0,8	82-178
MET030S380	3	340	250	142	231	10	0,4	1,0	100-180
MET050S380	5	400	291	142	231	10	0,75	1,8	110-180

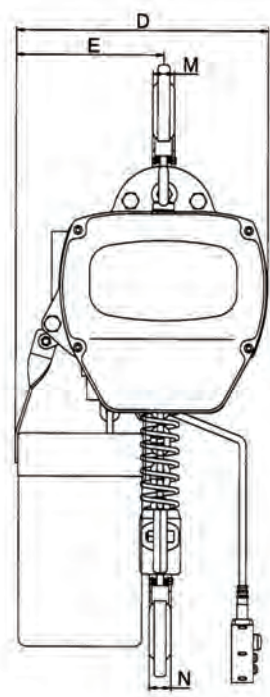
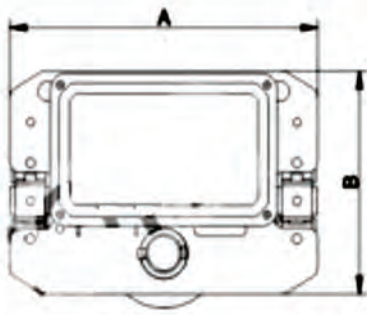
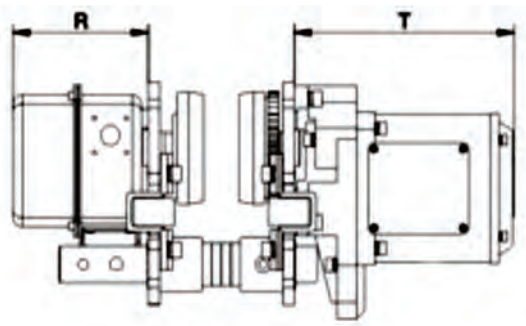



# SS11 SUBSEA LEVER HOIST

The original and proven subsea lever hoist - constantly developed and improved.

- Range from 800kg – 20000kg
- **\*NEW\* Patented Twin Cam shaped pawl design**
- Unique dual brake mechanism
- One piece construction pinion gears
- No requirement for pre-load tension to activate the ratchet mechanism
- Lifts, holds and lowers the load at 2% of rated capacity so no light load failures
- Over 1000 hours corrosion protection under ASTM B117 salt spray test conditions
- Certified and proven track record
- Overload protection available
- SANS 1636 compliant

The SS11 has been designed and developed to be certified for safe use Subsea, and is thus also suitable for most harsh and extreme applications.

It comes equipped with a unique dual brake mechanism that automatically engages when the lever hoist feels the slightest resistance on the bottom hook. This key feature means that the SS11 will raise, hold, and lower the lightest of loads without slipping. The two stage process protects against accidental light load failures caused by putting the hoist into neutral whilst under load.

The unique design features and anti-corrosion

properties incorporated in the SS11 hoist range, including the one piece construction pinion gears, give it significant safety advantages over standard lever hoists, making the hoist the ideal tool for all marine, mining and other extreme applications.

The SS11 meets and exceeds the requirements of IMCA DO28 Rev. 1 "Guidance on the use of chain lever hoists in the offshore subsea environment", as well as other industry client specifications whilst conforming to standards such as **BS EN 13157:2004, ANSI/ASME B30.21-2005, AS1418.2 and SANS 1636.**



Drop forged and heat treated wide opening alloy hooks incorporating heavy duty latch kits that fully engage into the nose of the hook offering maximum load security. Stainless steel fixings and fasteners used throughout the hoist.



Chain stripper specifically designed to guide the load chain safely onto or off the load sheave without snagging or jamming, allowing safe use in any orientation.



Tiger have incorporated the ultimate safeguarding of a single point failure mode by installing a new specially designed adjustable chain end stop profiled to fit the contours of the hoist body.



Unique dual brake mechanism.

## SPECIFICATIONS

Product Code	Capacity (ton)	Effort (kg)	Headroom (mm)	Load Chain		Standard HOL (m)	Mass @ std HOL (kg)	Mass for extra metre HOL (kg)
				Diameter (mm)	No. of falls			
SSU008	0.8	23	275	6.3	1	3	9.1	0.86
SSU015	1.5	26	320	7.1	1	3	12.6	1.10
SSU030	3.0	38	400	10.0	1	3	22.0	2.17
SSU060	6.0	40	570	10.0	2	3	36.5	4.34
SSU100	10.0	47	630	10.0	3	3	56.3	6.54
SSU200	20.0	43	1050	10.0	6	3	174.0	13.08

This unit can also be supplied to ATEX approved spark resistant specification.





# SS12 CORROSION RESISTANT CHAIN BLOCK

Unrivalled corrosion protection.

- Range 500kg – 30000kg
- **\*NEW\* Patented Twin Cam shaped pawl design**
- Fully corrosion protected body and components - over 1000 hours continuous protection
- Corrosion protected load and hand chain
- Marine specific friction discs

- Double cover protection for brake chamber
- Stainless steel fixings and fasteners
- Guaranteed 2% light load protection
- Overload protection available
- SANS 1594 compliant

Tiger chain blocks have been manufactured and developed for 50 years and offer the perfect balance between operator effort and speed of lift, ensuring maximum mechanical efficiency.

Using only the highest quality materials precisely machined in our own factory, the SS12 is the ideal block for use in salt water and other corrosive environments, with less maintenance and servicing costs.

The highly efficient and fully corrosion protected twin pawl brake works instantly when the

operation is stopped and securely holds the load. Loads are lowered under perfect control, allowing for precise operations.

The SS12 easily passes the "brake lock out test" as per BS 3243:1990 with a 2% load of the rated capacity.

These units meet and exceed all the requirements within **BS EN 13157:2004, ANSI/ASMEB30.21-2005, AS1418.2 and SANS 1594.**



Drop forged and heat treated wide opening alloy hooks incorporating heavy duty latch kits that fully engage into the nose of the hook offering maximum load security. Stainless steel fixings and fasteners used throughout the hoist.



Recessed forgings offer full protection to the load chain anchor bolts on all our bottom hooks. Load sheave protected design on all multi fall hooks.



Unique corrosion protection of all the internal parts including load and hand chain, ensuring over 1000 hours continuous protection under ASTM B117 salt spray test conditions.



Can be supplied to ATEX approved spark resistant specification.



## SPECIFICATIONS

Product Code	Capacity (ton)	Effort (kg)	Headroom (mm)	Load Chain		Standard HOL (m)	Mass @ std HOL (kg)	Mass for extra metre HOL (kg)
				Diameter (mm)	No. of falls			
SCU005	0.5	21	305	6.3	1	3	10.8	1.88
SCU010	1.0	25	340	6.3	1	3	11.8	1.88
SCU015	1.5	32	385	7.1	1	3	16.2	2.10
SCU020	2.0	34	420	8.0	1	3	20.0	2.40
SCU030	3.0	38	550	10.0	1	3	30.8	3.20
SCU050	5.0	37	575	8.0	3	3	37.8	5.20
SCU100	10.0	40	660	10.0	3	3	65.0	7.60
SCU200	20.0	43	1050	10.0	6	3	180.5	14.20
SCU300	30.0	42	1200	10.0	10	3	300.0	23.80



# PROLH LEVER HOIST

The professionals' choice incorporating our patented twin cam pawl design.

- Range 800kg - 20000kg
- Equipped with our unique dual brake mechanism
- Overload protection available
- One piece construction pinion gears
- Adaptable to use both inverted and horizontally
- \*NEW\* Patented Twin Cam shaped pawl design
- Light load tested and certified at 2% of the rated capacity and proof tested at 1.5 times the rated capacity
- Operating temperature range of - 40°C to + 50°C
- SANS 1636 compliant

PROLH lever hoists incorporate many of the advanced safety features that Tiger has developed, including their own unique dual brake mechanism that automatically engages when the lever hoist feels the slightest resistance on the bottom hook. This key feature means that the PROLH will raise, hold, and lower the lightest of loads without slipping.

The two stage process protects against accidental light load failures caused by putting the hoist into neutral whilst under load. This includes operations

that require a hoist to be used horizontally, inverted, or at any angle.

The PROLH is ideally suited for applications in the overhead transmission industry, shipyards, offshore platforms and is also suitable for underground mining use.

These units meet and exceed all the requirements within **BS EN 13157:2004**,

**ANSI/ASME B30.21-2005, AS1418.2 and SANS 1636.**



Drop forged and heat treated wide opening alloy hooks incorporating heavy duty latch kits that fully engage into the nose of the hook offering maximum load security.



Chain stripper specifically designed to guide the load chain safely onto or off the load sheave without snagging or jamming, allowing safe use in any orientation.



Unique dual brake mechanism with anti-tamper design, shown in "freewheel" and "brake engaged" positions. Available with overload protection.



Product Code	Capacity (ton)	Effort (kg)	Headroom (mm)	Load Chain		Standard HOL (m)	Mass @ std HOL (kg)	Mass for extra metre HOL (kg)
				Diameter (mm)	No. of falls			
TLU008	0.8	22	275	6.3	1	1.5	7.6	0.86
TLU015	1.5	26	320	7.1	1	1.5	10.7	1.10
TLU030	3.0	38	400	10.0	1	1.5	18.2	2.17
TLU060	6.0	40	570	10.0	2	1.5	29.7	4.34
TLU100	10.0	47	630	10.0	3	1.5	45.7	6.54
TLU200	20.0	43	1050	10.0	6	3	174.0	13.08



# TCB CHAIN BLOCK

The classic heavy duty light weight chain block.

- Range from 500kg - 30000kg
- Double cover protection for brake chamber
- **\*NEW\* Patented Twin Cam shaped pawl design**
- Guaranteed 2% light load protection and proof tested to 1.5 times rated capacity
- Overload protection available
- Tested and certified for "fleeting" and "cross-hauling" applications
- Safe reliable independent twin pawl mechanical brake
- Heat treated alloy steel triple spur gears and pinion shaft
- Minimal overhaul effort
- SANS 1594 compliant

Manufactured and evolved over 50 years, Tiger chain blocks offer the perfect balance between operator effort and speed of lift, ensuring maximum mechanical efficiency. The short head room allows for easy installation where space is limited. Using the highest quality steel materials, the TCB is a lightweight, compact and rugged construction. All major components are heat treated and precisely machined to

ensure long term smooth operation. The strong impact resistant gearbox housing has close tolerance fit bearings that fully support the pinion shaft and planet gears, to maintain smooth revolutions under load. These units meet and exceed all the requirements within **BS EN 13157:2004, ANSI/ASME B30.21-2005, AS1418.2 and SANS 1594.**



Drop forged and heat treated wide opening alloy hooks incorporating heavy duty latch kits that fully engage into the nose of the hook offering maximum load security.



Recessed forgings offer full protection to the load chain anchor bolts on all our bottom hooks.



Strong and contoured chain end anchor will hold a load of at least 2.5 times the rated capacity when supporting the full load without restraint from other components e.g. brake or gearing. This prevents accidents, by acting as a stop when the lift length of the load chain is exceeded when lowered.



The fine tolerance deep pockets on the hand wheel ensure positive engagement of the hand chain at all times for smooth operation. Overload protection available.



Shown with optional corrosion resistant load chain.

Product Code	Capacity (ton)	Effort (kg)	Headroom (mm)	Load Chain		Standard HOL (m)	Mass @ std HOL (kg)	Mass for extra metre HOL (kg)
				Diameter (mm)	No. of falls			
TCU005	0.5	21	305	6.3	1	3	10.8	1.86
TCU010	1.0	25	340	6.3	1	3	11.8	1.86
TCU015	1.5	32	385	7.1	1	3	16.2	2.10
TCU020	2.0	34	420	8.0	1	3	20.0	2.39
TCU030S	3.0	38	550	10.0	1	3	30.8	3.17
TCU030	3.0	34	465	7.1	2	3	23.3	3.20
TCU050	5.0	37	575	8.0	3	3	37.8	5.17
TCU080	8.0	37	745	8.0	4	3	67.0	6.56
TCU100	10.0	40	660	10.0	3	3	65.0	7.54
TCU150	15.0	41	840	10.0	5	3	131.4	11.85
TCU200	20.0	43	1050	10.0	6	3	180.5	14.20
TCU300	30.0	42	1200	10.0	10	3	300.0	23.80

# ILULA®



## ILULA CHAIN BLOCK

Robust & dependable chain block that is economical & lightweight

- Range from 500kg - 20,000kg
- Double pawl braking system
- Extra-thick asbestos-free friction plates
- **Anti-slip hooks providing extra safety with heavy duty cast safety latches**
- Full spares back-up for maintenance purposes
- Drop forged top & bottom hooks that can rotate 360°
- Designed to international standards. Generally compliant to SANS
- Units can be chained for any height of lift required
- Overload protection available on request
- Each unit is tested to 125% of the rated capacity
- **Serial numbered for traceability**
- **Supplied with individual test certificate**



Product Code	Capacity (ton)	Effort (kg)	Load Chain		Mass @ std 3m lift (kg)	Mass for extra metre HOL (kg)
			Diameter (mm)	No. of falls		
ICU005	0.5	20	6.0	1	8.0	1.7
ICU010	1.0	33	6.0	1	12.0	1.7
ICU015	1.5	37	8.0	1	18.0	2.3
ICU020	2.0	37	8.0	1	18.0	2.3
ICU030	3.0	39	8.0	2	25.0	3.7
ICU030S	3.0	42	10.0	1	28.0	3.1
ICU050	5.0	44	10.0	2	45.0	5.4
ICU100	10.0	44	10.0	4	79.0	9.7
ICU200	20.0	44 x 2	10.0	8	193.0	19.4

**OVERLOAD PROTECTION**

Available on request

**ASSEMBLED & TESTED IN SOUTH AFRICA**

# ILULA®



## ILULA LEVER HOIST

Robust & dependable lever hoist that is economical & lightweight

- Range from 750kg - 9,000kg
- Double pawl braking system
- Extra-thick asbestos-free friction plates
- **Anti-slip hooks providing extra safety with heavy duty cast safety latches**
- Time saving rapid free-wheeling system for fast hook-ups
- Full spares back-up for maintenance purposes
- Drop forged top & bottom hooks that can rotate 360°
- Designed to international standards. Generally compliant to SANS
- Units can be chained for any height of lift required
- Overload protection available on request
- Each unit is tested to 125% of the rated capacity
- **Serial numbered for traceability**
- **Supplied with individual test certificate**

Product Code	Capacity (ton)	Effort (kg)	Load Chain		Mass @ std 3m lift (kg)	Mass for extra metre HOL (kg)
			Diameter (mm)	No. of falls		
ILU075	0.75	14	6.0	1	8.0	0.9
ILU150	1.5	22	8.0	1	13.0	1.4
ILU300	3.0	32	10.0	1	22.0	2.2
ILU600	6.0	34	10.0	2	36.0	4.4
ILU900	9.0	36	10.0	3	53.0	6.6

**OVERLOAD PROTECTION**

Available on request

**ASSEMBLED & TESTED IN SOUTH AFRICA**



# MAXICRAWL®



## PLAIN & GEARED CRAWLS

Crawls are easily adjustable to suit a wide range of beam widths & feature robust construction.



PLAIN

GEARED

Maxicrawl hoist crawls or trolleys are available in a push or hand geared versions. The hand chain fitted to the hand geared unit can be supplied to suit the height of lift required. The units can be adjusted to suit the width of any I-beam or H-beam. Extended shafts are available on request.

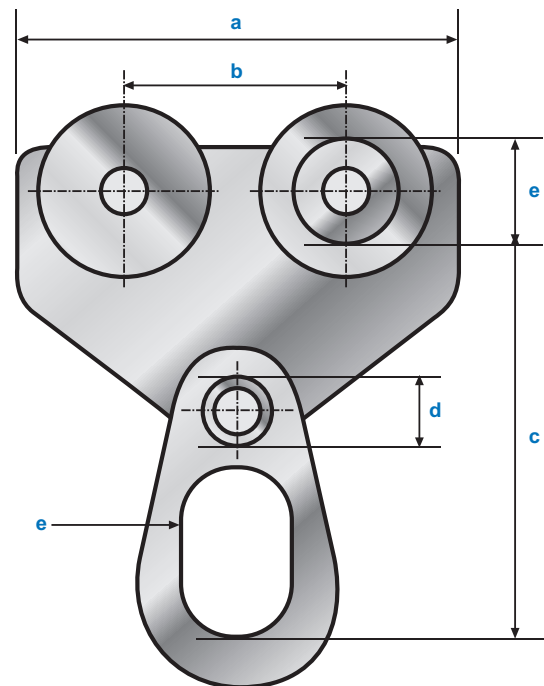

Dimensions		Capacity						
		1/2 Ton	1 Ton	2 Ton	3 Ton	5 Ton	10 Ton	20 Ton
Item Code	Plain	CRP005	CRP010	CRP020	CRP030	CRP050	CRP100	CRP200
	Geared	N/A	CRG010/3M	CRG020/3M	CRG030/3M	CRG050/3M	CRG100/3M	CRG200/3M
a	Overall Length	210mm	210mm	260mm	295mm	345mm	525mm	525mm
b	Distance Between Axles (Centre to Centre)	100mm	100mm	125mm	145mm	170mm	255mm	255mm
c	Distance Between Beam Base & Hook Bearing Point	145mm	145mm	135mm	170mm	195mm	210mm	250mm
d	Shaft Diameter	20mm	22mm	25mm	30mm	39mm	30mm	54mm
e	Load Wheel Diameter (At Load Bearing Surface)	54mm	54mm	80mm	105mm	115mm	200mm	200mm
f	Internal Width & Height of Suspension Eye	47mm	47mm	50mm	49x69mm	50x78mm	79x120mm	88x120mm

\* Geared Code for 3m Hand Chain

Specifications		Capacity						
		1/2 Ton	1 Ton	2 Ton	3 Ton	5 Ton	10 Ton	20 Ton
Side Plate Thickness		8mm	10mm	10mm	12mm	16mm	20mm	30mm
Weight	Plain	8kg	9kg	15kg	25kg	40kg	139kg	N/A
	Geared	N/A	10kg	17kg	27.5kg	45kg	146kg	237kg
To Fit Beam Width	Minimum	76mm	76mm	92mm	92mm	125mm	138mm	145mm
	Maximum	138mm	138mm	152mm	152mm	191mm	230mm	305mm
Minimum Radius		1.3m	1.3m	1.5m	2.0m	2.5m	3.5m	3.5m

# ROLACRAWL®



## PLAIN & GEARED CRAWLS

Rolacrawl Crawls are easily adjustable to suit a wide range of beam widths.



Rolacrawl hoist crawls or trolleys are available in a push or hand geared versions. The hand chain fitted to the hand geared unit can be supplied to suit the drop required. The units can be precisely adjusted to suit the width of any I-beam or H-beam using the counter-threaded bolt which ensures that the load is centred, preventing sideward movement on the beam.

PLAIN

GEARED

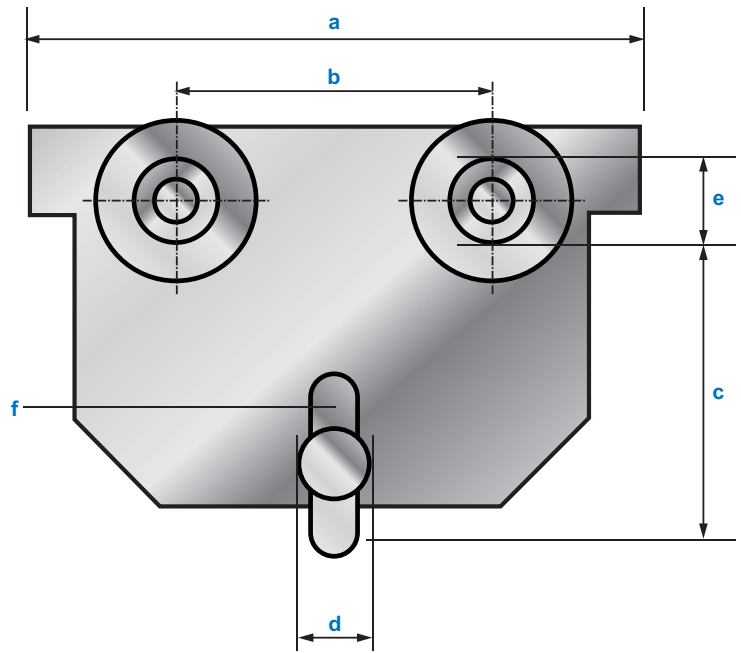

Approximate Dimensions		Capacity				
		1/2 Ton	1 Ton	2 Ton	3 Ton	5 Ton
Item code	Plain	CRRP005	CRRP010	CRRP020	CRRP030	CRRP050
	Geared*	N/A	CRRG010/3M	CRRG020/3M	CRRG030/3M	CRRG050/3M
<b>a</b>	Overall Length	198mm	245mm	277mm	330mm	380mm
<b>b</b>	Distance Between Axles (Centre to Centre)	100mm	120mm	130mm	160mm	170mm
<b>c</b>	Distance Between Beam Base & Hook Bearing Point	80mm	105mm	125mm	150mm	160mm
<b>d</b>	Shaft Diameter	24mm	30mm	36mm	41mm	47mm
<b>e</b>	Load Wheel Diameter (At Load Bearing Surface)	55mm	67mm	80mm	100mm	110mm
<b>f</b>	Internal Width & Height of Suspension Eye	24x30mm	30x35mm	40x47mm	44x57mm	50x64mm

\* Geared Code for 3m Hand Chain

Approximate Dimensions		Capacity				
		1/2 Ton	1 Ton	2 Ton	3 Ton	5 Ton
Side Plate Thickness		6mm	8mm	10mm	12mm	16mm
Weight	Plain	5kg	9kg	14.5Kg	23.5kg	36.5kg
	Geared	N/A	10kg	15.5kg	25kg	38.5kg
To fit beam width - Minimum		50mm	58mm	66mm	74mm	90mm
To fit beam width - Maximum		220mm	220mm	220mm	220mm	220mm
Minimum Radius		1.3m	1.3m	1.5m	2.0m	2.5m



# PLAIN & GEARED TROLLEYS

Tiger trolleys are designed to provide smooth and easy traversing

## Plain Trolley - BTPT

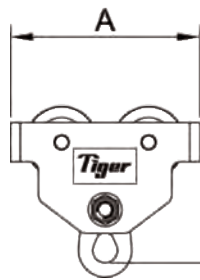

Single Bar

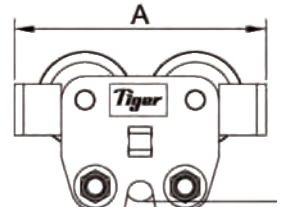
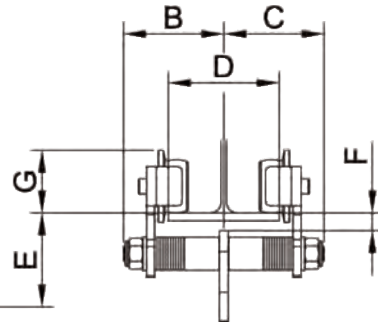

Twin Bar

- Plain trolley range from 0.5t to 5t (single bar) and 10t (twin bar)
- The anti-drop plates design ensures extra safety, and also prevents damage to wheels when contacting end rail stoppers

### Technical Specifications

Product Code	Capacity (ton)	D Track Width Range (mm)	Dimensions (mm)					Min. Curve Ratio (mm)	Net Weight (kg)	
			A	B	C	E	F			G
BTPT005	0.5	62-203	195	106	106	98	20	64	0.8	5.0
BTPT010	1.0	62-203	213	113	113	106	20	71	1.0	7.5
BTPT020	2.0	88-230	236	136	136	132	25	80	1.3	12.0
BTPT030	3.0	88-230	270	146	146	150	25	97	1.5	19.5
BTPT050	5.0	106-305	323	169	169	174	30	117	1.5	30.5
BTPT100	10.0	N/A	460	225	225	248	42	182	2.7	135.5

- Wheels run on sealed ball bearings for smoother rolling with less effort and maintenance
- Geared type trolleys from 1t to 10t available (with 3m hand chain length)
- Extended beam width available
- Operating temperature of -30°C to +50°C (temperature range of -50°C to +50°C available as an option)
- 5:1 factor of safety allows for use with manual or powered hoists

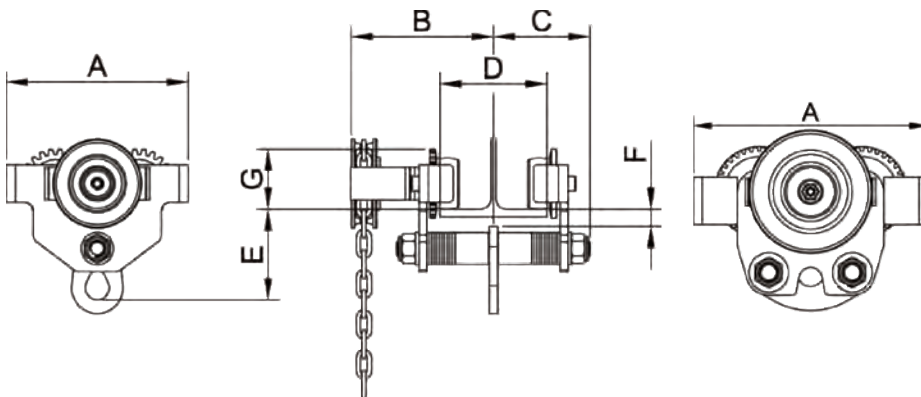

## Geared Trolley - BTGT



### Technical Specifications

Product Code	Capacity (ton)	D Track Width Range (mm)	Dimensions (mm)					Min. Curve Ratio (mm)	Net Weight (kg)	
			A	B	C	E	F			G
BTGT010/3M	1.0	75-210	391	83.5	16	110	81	255-208	1.0	TBA
BTGT020/3M	2.0	75-210	391	94.5	18	123	89	255-208	1.3	TBA
BTGT030/3M	3.0	75-210	403	105.5	22	141	112	276-227	1.5	28.5
BTGT050/3M	5.0	105-305	521	111	27	151.5	125	288-241	1.5	40.0
BTGT100/3M	10.0	160-305	606	19	32	170	83	400-340	2.7	221.0

Standard geared trolley hand chain length - 3.0m. We can change the length to suit your requirements.



# ADJUSTABLE TROLLEYS & LIFTING BEAM CLAMPS

Tiger trolleys are designed to provide smooth and easy traversing, Tiger Universal Beam Clamp are suitable for lifting at any angle

## Adjustable Trolley - BTPT



- Range from 1t to 6t
- Fitted with a screw spindle which allows easy adjustment and high clamping force to the various flange sizes within its capacity

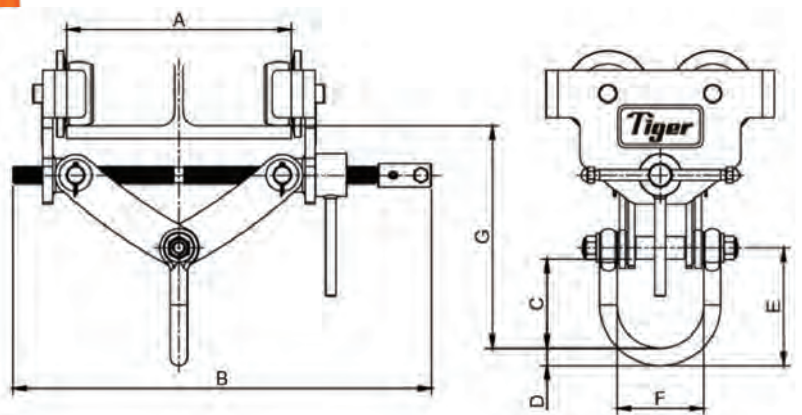

### Technical Specifications

Product Code	Capacity (ton)	A Track Width Range (mm)	Dimensions (mm)						Min. Curve Ratio (mm)	Net Weight (kg)
			B	C	D	E	F	G		
BTPT005	0.5	75-210	391	83.5	16	110	81	TBA	1.0	9.6
BTPT010	1.0	75-210	391	94.5	18	123	89	255-208	1.3	13.5
BTPT020	2.0	75-210	403	105.5	22	141	112	276-227	1.5	23.0
BTPT030	3.0	105-305	521	111	27	151.5	125	288-241	1.5	35.5
BTPT050	5.0	105-305	521	111	27	151.5	125	358-290	1.5	40.1
BTPT100	10.0	160-305	606	119	32	170	83	400-340	2.7	118.0

- The anti-drop plates design ensures extra safety, and also prevents damage to wheels when contacting end rail stoppers
- Wheels run on sealed ball bearings for smoother rolling with less effort and maintenance
- Operating temperature of -30°C to +50°C (temperature range of -50°C to +50°C available as an option)
- The 5:1 factor of safety allows for use with manual or powered hoists

## Universal - BTBCU



- Full rated capacity at any lifting angle
- 3t and 5t capacities available
- Quick and versatile rigging point for hoisting equipment
- Low headroom design
- Highly flexible- for lifting, pulling or as a semi-permanent anchor point
- Designed for both vertical and side loading applications -can be loaded at any angle
- Suitable for pulling and lifting at angles across the beam
- Designed to accommodate a wide range of beam widths
- Multidirectional adjusting screw spindle ensures a high clamping force to beam web
- Operating temperature of -50°C to +50°C
- 4:1 factor of safety
- Complies with ASME B30.20 and EN13155 :2003+A2 :2009

### Technical Specifications

Product Code	Capacity (ton)	L Track Width Range (mm)	Dimensions (mm)										Net Weight (kg)
			A	B	C	D	E	F	G	H	J	K	
BTBCU030	3.0	125-204	387	60	70	63	32	235	100	25	28	20	15.5
BTBCU050	5.0	125-305	524	70	74	72	32	270	120	25	28	40	27.0

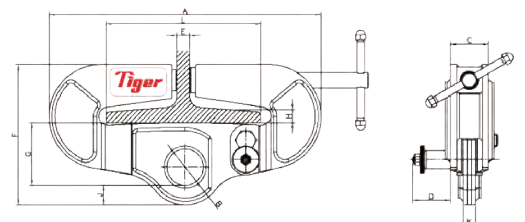

**Warning: Do not exceed working load limits or use this equipment for lifting flat plate sections**



# BEAM CLAMPS

These units meet and exceed all the requirements within BS EN 13155:2003+A2:2009 and AS4991.

## Heavy Duty - BTBCF



Heavy Duty Fixings & Marking

- Range from 3t to 5t
- Quick and versatile rigging point for hoisting equipment
- Shackle suspension point
- Suitable for pulling and lifting at angles across the beam
- Up to 90° side loading with no deration
- 15° cross loading with no deration
- Highly flexible - for lifting, pulling or as a semi-permanent anchor point
- Evenly distributed loads achieved through maximum jaw surface area
- Multidirectional adjusting screw spindle ensures a high clamping force to the various flange sizes within its capacity
- Beam width range 100mm to 350mm
- Operating temperature of -50°C to +50°C
- 4:1 factor of safety
- Optional locking device
- Complies with BS EN 13155:2003 + A2:2009 and AS4991

### Technical Specifications

Product Code	Capacity (ton)	A Track Width Range (mm)	Dimensions (mm)										Net Weight (kg)
			B	C	D	E	F	G	H	J	K	L	
BTBCF030	3.0	100-350	223-476	140	25	270	418-344	22	27	110	105	10	12.0
BTBCF050	5.0	100-310	223-438	140	25	286	424-368	27	27	124	111	12	14.5

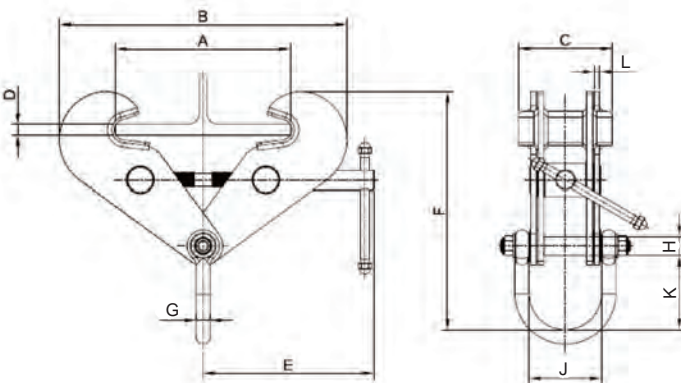

## Adjustable Angle - BTBCA



- 1t and 3t capacities available
- Quick and versatile rigging point for hoisting equipment when attached to overhead steel angle section approved for lifting applications
- Shackle suspension point
- V shaped clamping jaws ensures safe and secure grip
- Designed to accommodate a wide range of steel angle sections
- No tools required -integrated adjusting screw spindle
- Operating temperature of -50°C to +50°C
- 4:1 factor of safety
- Complies with BS EN 13155:2003 + A2:2009 and AS4991

### Technical Specifications

Product Code	Capacity (ton)	K Track Width Range (mm)	Dimensions (mm)								Net Weight (kg)
			A	B	C	D	E	G	H	J	
BTBCA010	1.0	38-101	6	76	81	83	206	258	16	105	5.5
BTBCA030	3.0	101-203	10	106	112	104	343	490	22	111	23.5

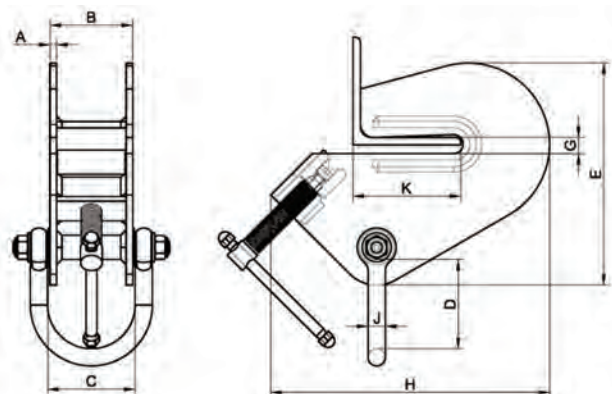



Order hook & cable separately

# INDUSTRIAL HAND WINCH

Model No. SF-2200

- 1000kg lifting & 2000kg pulling capacity
- Ratchet handle permits reciprocating handle movement in both directions for lifting and lowering loads
- Positive load-actuated brake can hold the load in any position
- Gears and brake are fully covered to prevent dust, dirt and rain contamination
- Very low operator effort is required for easy operation
- Ratchet handle accommodates installation in cramped locations

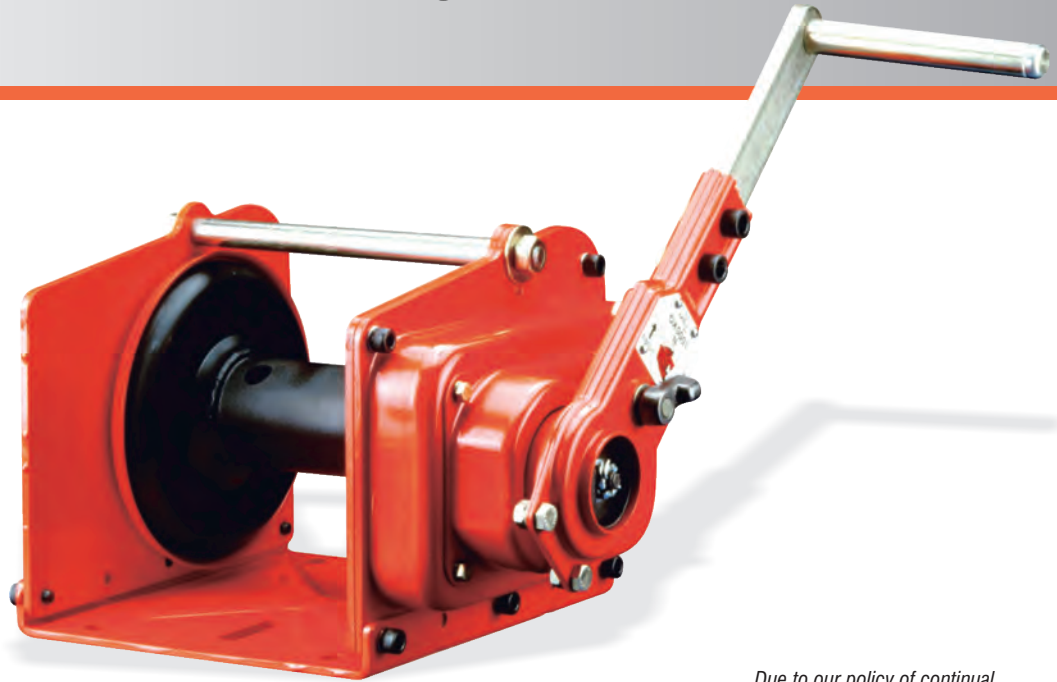

## Technical Specifications

Product Code	Pulling Capacity (kg)	Lifting Capacity (kg)	Hand Force Required (kg)	Gear Ratio	Hub Ø (mm)	Handle Length (mm)	Unit Weight With Handle (kg)	Cable Ø (mm)	Cable Capacity (m)
HWI1000	2000	1000	10	22.2:1	80	300	17.5	8.0	35

*Due to our policy of continual product development, dimensions, weights and specifications may change without prior notice. Please check with your sales team when ordering.*

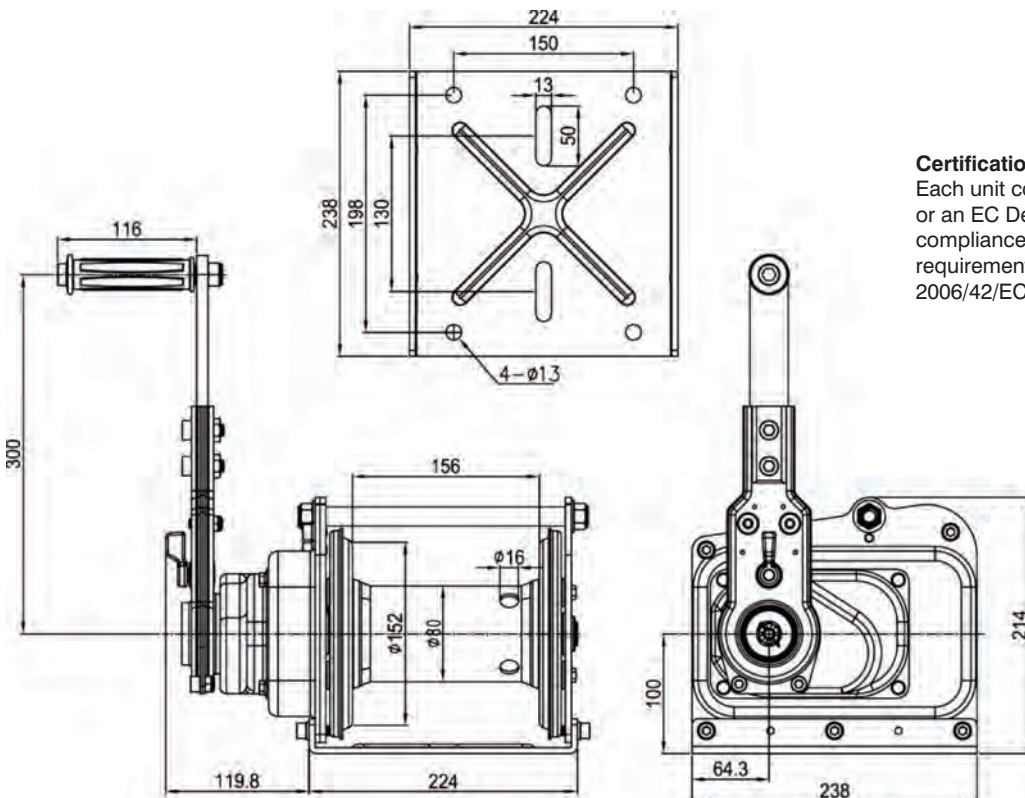

### Certification:

Each unit comes fully certified with a test certificate or an EC Declaration of Conformity stating compliance with the essential health and safety requirements of the Machinery Directive 2006/42/EC.

**SGS**





**HARU®**



# FALL ARRESTORS

A range of retractable lifelines that reduces the shock loading on the body by limiting the distance of fall. Used in work inspection, general construction, maintenance, oil production, telecommunications, mining and confined work areas.

HARU® Fall Arrestors provide continuous protection against falls. The Fall Arrestor automatically extends and retracts to allow freedom of movement. Each unit includes anchorage ropes.

HARU® Fall Arrestors are manufactured in a ISO 9001:2008 factory and all products are CE approved.



**FAHB03,5N**



Patented Safety Mechanism



**FAHB06N**



**FAHB10**

**FAHB06**



**FAHB15**



**FAHB20**

## SPECIFICATIONS - FALL ARRESTORS - EN360 APPROVED

Model Number	Type	Length (m)	Weight (kg)
FAHB03.5N	Nylon Webbing	3.5	1.6
FAHB06N	Nylon Webbing	6	1.6
FAHB06	Steel wire rope	6	4.5
FAHB10	Steel wire rope	10	4.8
FAHB15	Steel wire rope	15	6.6
FAHB20	Steel wire rope	20	8.6

### CAUTION!



Always read the instruction manual before use. Always wear the correct safety gear.

## TRIPOD

**FATPC**

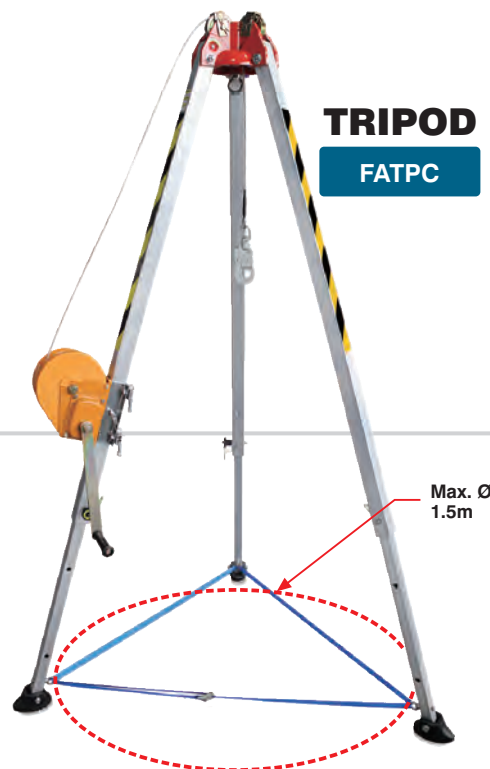

## SPECIFICATIONS - TRIPOD - EN795 APPROVED

Model Number	Material	Height (M)	Wire Dia. x Length	Safe Load (kg)	Weight (kg)
FATPC	Aluminium	1.35 - 2.40	5mm x up to max. 30m	100	20.0 (Excl. Rope)

For confined space and rescue applications. Adjustable height. Additional cable pulley and point to attach to retractable lifeline. For manhole max. diameter 1.5m and under.



# Tiger



## PERSONAL FALL PROTECTION BEAM ANCHORS

Tiger Beam Anchors are used as anchorage connectors for personal fall arrest systems & meet the requirements of SANS 50795 and EN 795

Designed to be attached to Horizontal I-Beams with an attached personal fall arrest system jaw sliding clamp can also be attached to vertical I-Beams.

(full body safety harness, shock absorbing lanyard or fall arrest block). The Tiger single Minimum breaking strength 22.3kN

Designed for one person use only with a maximum capacity of 140kg

Model Number

**FABASJ**

Single Jaw Sliding  
Fixed Beam Anchor



Model Number

**FABADJ**

Two Jaw Sliding  
Fixed Beam Anchor



Model Number

**FABART**

Mobile Two Jaw Sliding  
Mobile Beam Anchor

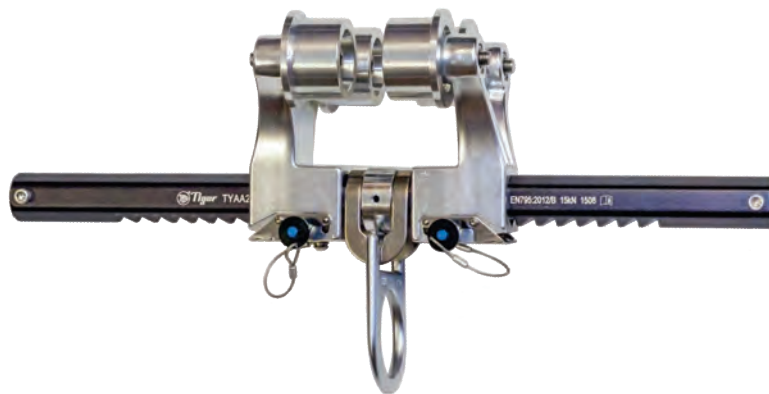

### Technical Data

Product Code	Description	Beam Flange Size	Length (mm)	Height (mm)	Width (mm)	Weight (kg)
FABASJ45	Fixed Type Single-Jaw Sliding Horizontal & Vertical Beam Use	63.5 - 450mm	684	209	76	2.83
FABADJ45	Fixed Type Two-Jaw Sliding Horizontal Beam Use	63.5 - 450mm	643	199	76	2.22
FABART45	Mobile (rolling) Type Two-Jaw Sliding Horizontal Beam Use	63.5 - 450mm	643	239	140	3.28

Beam Anchors for larger beams available on request



# FALL ARRESTORS

Heavy duty MAXIPROTECT Fall Arrest Retractable Lifelines are designed to reduce vertical impact force on the body caused by falling from height.

MAXIPROTECT® Fall Arrestors provide continuous protection against falls. The Fall Arrestor automatically extends and retracts to allow freedom of movement.

MAXIPROTECT® Fall Arrestors are manufactured in a ISO 9001:2008 factory and all products are CE approved. Maximum rated load of 150kg.



Triple pawl brake system



## SPECIFICATIONS - FALL ARRESTORS EN360 APPROVED

Model Number	Type	Dia./Width of rope (mm)	Length (m)	Weight (kg)
FAMP10	Steel wire rope	4.8	10	6.5
FAMP15	Steel wire rope	4.8	15	8.0
FAMP20	Steel wire rope	4.8	20	10.8

- High strength ABS (thermoplastic) casing
- 150kg capacity for operator and tools
- Triple pawl brake system with energy dissipating mechanism
- Lightweight, compact and durable
- Conforms to EN 360:2002 (SANS 50360:2003)
- Minimum static strength 15kN
- Side cable exit for smooth operation and reduced cable wear

- Top anchor point with built-in swivel limits lifeline twisting
- Buffer spring at cable exit protects block and allows for smooth operation
- Lower self-locking snap hook and swivel with built-in impact indicator for connecting directly to the safety harness
- Available in 10M, 15M and 20M wire rope lengths
- Supplied with pull down cord



**HARU®**

# FALL ARRESTORS

## Operating Guidelines

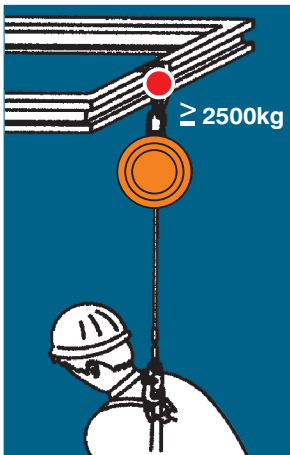

- Use a rigid anchor point capable of carrying at least 2500kg
- **DO NOT WORK ABOVE THE ANCHOR POINT**

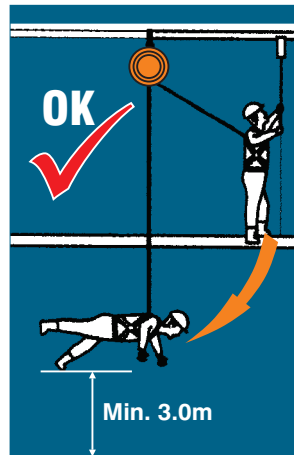

- The minimum working height is calculated by adding 3.0m to the length of the fall of the rope

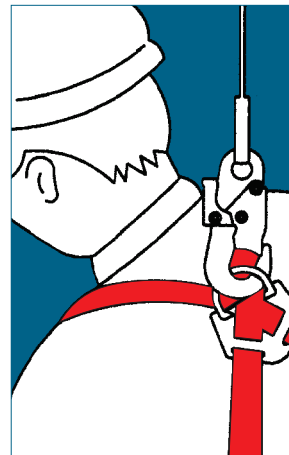

- The Fall Arrestor must be used in conjunction with a full body harness which conforms to EN361 and all connectors must conform to EN362

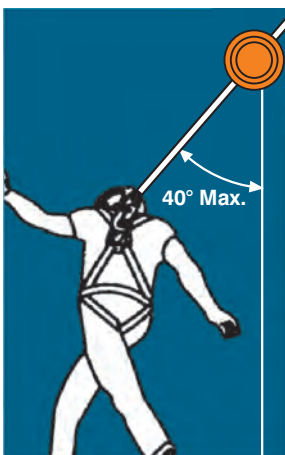

- Use at up to 40°
- **DO NOT WORK HORIZONTALLY TO THE FALL ARRESTOR**

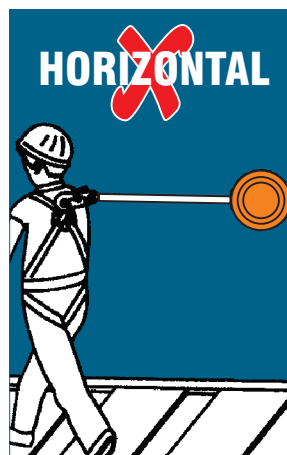

### CAUTION!



Always read the instruction manual before use  
Always wear the correct safety gear



# VITALIFT®



## LIFTING APPLIANCES

A range of versatile lifting appliances, essential for materials handling applications around the warehouse and store yard.

### DRUM LIFTERS



HORIZONTAL

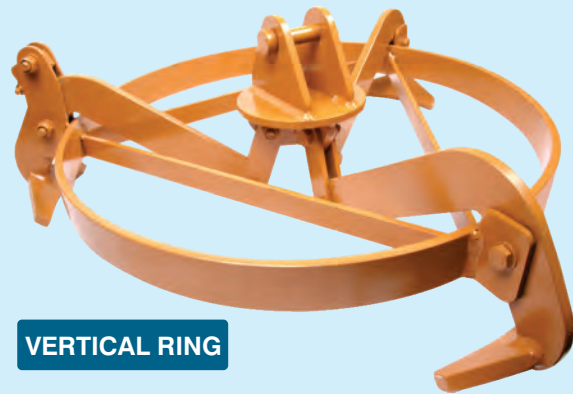

VERTICAL RING



VERTICAL

DRUM HOOKS

### FORKLIFT HOOKS

SINGLE

1 & 2 Ton



DOUBLE

3 Ton

### MANHOLE RING LIFTING SYSTEM

A standard lifting system which consists of a 3 legged chain sling attached to 3 lifting clamps.



#### SPECIFICATIONS

Minimum Ring Diameter	Wall Thickness Range	Maximum Weight
900mm	40-125mm	2400Kg

Clamps available individually  
Purchase 3 legged chain sling separately

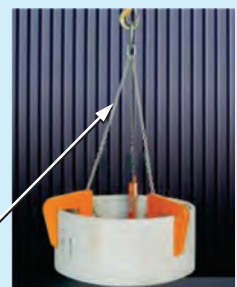

# ILULA®

## CONTAINER LIFTING SYSTEM

For lifting partially filled or empty six metre steel containers.



Lifting Beam

Chain Sling

Easy-fit Lifting Lug

**WORKING LOAD LIMIT  
PER LUG: 12'500 Kg  
SAFETY FACTOR: 4:1**

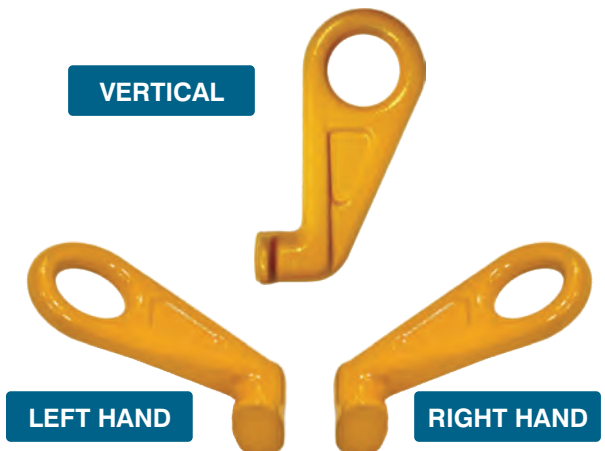

- Standard system capacities:
- 3 Tons
  - 6 Tons
  - 10 Tons

# ILULA®

## EXCAVATOR WELD-ON HOOKS

Also known as Utility Hooks



Working Load Limit (Kg)	Throat Clearance (mm)	Length of Base (mm)	Approx. Weight (Kg)
1000	23	98	0.5
2000	30	81	0.8
3000	33	116	1.2
5000	39	159	2.5
8000	35	159	3.3
10000	50	194	5.2



**SAFETY FACTOR: 5:1**



# PLATE GRABS

A range of heavy duty steel plate grabs designed for lifting plate steel in industrial applications. Lift, lower and position with complete safety.



## VERTICAL

- Vitalift Vertical Plate Grabs are suitable for the vertical lifting of plate steel up to 50mm thick
- Strong welded construction
- Spring-loaded mechanism ensures a positive initial clamping force
- Serrated grab teeth
- Spares available on request

Working Load Limit (Kg)	Jaw Opening (mm)	Eye Diameter (mm)	Net Weight (Kg)
1000	0 - 18	84	6
2000	0 - 28	78	16
3000	0 - 30	75	16
5000	5 - 50	86 x 129	39

Working Load Limit Per Pair (Kg)	Jaw Opening (mm)	Eye Diameter (mm)	Net Weight Per Pair (Kg)
1000	0 - 60	29 x 46	20
3000	0 - 100	45 x 68	43
6000	0 - 100	45 x 68	52
10000	50 - 150	60 x 68	93



## HORIZONTAL

- Vitalift Horizontal Plate Grabs are suitable for secure lifting of plate steel up to 150mm thick in a horizontal position
- Grabs have an enlarged jaw opening
- Serrated grab teeth
- Used in pairs
- Spares available on request



## UNIVERSAL

- Vitalift Universal Plate Grabs are suitable for secure bi-directional lifting of plate steel up to 50mm thick
- Articulated lifting shackle
- Spring-loaded mechanism ensures a positive initial clamping force
- Serrated grab teeth
- Spares available on request

Working Load Limit (Kg)	Jaw Opening (mm)	Eye Diameter (mm)	Net Weight (Kg)
1000	0 - 18	69	7.4
2000	0 - 28	72	18
3000	0 - 30	74	18
5000	0 - 50	79	44



# HORIZONTAL PLATE GRABS

Horizontal lifting clamps designed according to EN13155.  
Lift, lower and position with complete safety.

Minimum working load to be lifted is 10% of working load limit. Maximum permitted surface hardness of item to be lifted is 300 HB (HRC 32).  
Spares are available.



## HORIZONTAL

- Horizontal plate grabs are suitable for lifting of steel plates in the horizontal position
- Serrated grab teeth
- Used in pairs
- Spares available on request

Product Code	Working Load Limit Per Pair (Kg)	Minimum Load Per Pair (Kg)	Jaw Opening (mm)	Eye Diameter (mm)	Net Weight Per Pair (Kg)
MGH01500	1500	150	0 - 30	30	8
MGH03000	3000	300	0 - 45	30	12
MGH04000	4000	400	0 - 50	30	13
MGH05000	5000	500	0 - 55	30	15
MGH08000	8000	800	0 - 100	55	44



## HORIZONTAL ADJUSTABLE

- The horizontal plate clamps offer superb flexibility because of the large adjustable jaw opening
- The jaw is adjusted using a simple ratchet mechanism
- These clamps are to be used in pairs and are especially suited to the transportation of large plate bundles

Product Code	Working Load Limit Per Pair (Kg)	Minimum Load Per Pair (Kg)	Jaw Opening (mm)	Eye Diameter (mm)	Net Weight Per Pair (Kg)
MGHA06000	6000	600	0 - 240	36	40
MGHA15000	15000	1500	0 - 240	51	72



## HORIZONTAL SPLIT JAW

- The split lower jaw is particularly suitable for gripping steel I-Beams and girders regardless of whether from the side or the end
- Safety latch system can be locked closed

Product Code	Working Load Limit Per Pair (Kg)	Minimum Load Per Pair (Kg)	Jaw Opening (mm)	Eye Diameter (mm)	Net Weight Per Pair (Kg)
MGHSJ03000	3000	300	0 - 38	58	10



## HORIZONTAL PIPE PLATE GRABS

- Pipe plate clamps for horizontal lifting of steel and concrete pipes
- Lifting surface is equipped with plastic inserts to prevent damage

Product Code	Working Load Limit Per Pair (Kg)	Minimum Load Per Pair (Kg)	Jaw Opening (mm)	Eye Diameter (mm)	Net Weight Per Pair (Kg)
MGHPP03000	3000	300	40	27	6





# MAXIGRAB®



## PLATE GRABS & DRUM LIFTER

Lifting clamps designed according to EN13155.  
Lift, lower and position with complete safety.

Minimum working load to be lifted is 10% of working load limit. Maximum permitted surface hardness of item to be lifted is 300 HB (HRC 32).  
Spares are available.



### VERTICAL

- Vertical Plate Grabs are suitable for the vertical lifting of plate steel up to 60mm thick
- Grabs are equipped with a safety mechanism, ensuring the grab does not slip when the lifting force is applied and when the load is being lowered
- Spring-loaded tightening lock mechanism ensures a positive initial clamping force

Product Code	Working Load Limit (Kg)	Minimum Load (Kg)	Jaw Opening (mm)	Eye Diameter (mm)	Net Weight Per Pair (Kg)
MGV1000	1000	100	0 - 22	50	3.6
MGV2000	2000	200	0 - 30	54	5.5
MGV3000	3000	300	0 - 40	60	10
MGV5000	5000	500	5 - 45	68	17
MGV8000	8000	800	0 - 60	65	26



### UNIVERSAL

- Universal Plate Grabs are suitable for secure bi-directional lifting of plate steel up to 45mm thick
- Equipped with a pre-tension mechanism ensuring the grab does not slip when the lifting force is applied and when the load is being lowered

Product Code	Working Load Limit (Kg)	Minimum Load (Kg)	Jaw Opening (mm)	Eye Diameter (mm)	Net Weight Per Pair (Kg)
MGU1000	1000	100	0 - 20	50	5
MGU2000	2000	200	0 - 25	68	8
MGU3000	3000	300	0 - 30	75	15
MGU5000	5000	500	0 - 50	68	23
MGU8000	8000	800	0 - 45	88	37



### DRUM LIFTER

- Drum lifter has been designed to lift and transport drums in the vertical position with or without lids by gripping the rim of the drum
- Its light weight and small overall design makes it ideal for picking up drums that sit tightly on pallets
- The centre of gravity of the drum is directly below the lifting point during transportation

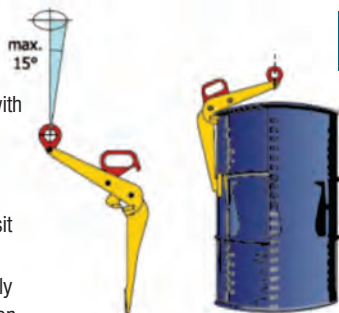

Item Code	Working Load Limit (kg)	Eye Diameter (mm)	Net Weight (Kg)
MGDLV	600	50	7

# MAXICLAMP®

## BEAM CLAMPS



Item Code	Working Load Limit (kg)	Adjustable Beam Width (mm)	Net Weight (Kg)
MC01	1000	75 - 220	4.5
MC02	2000	75 - 220	5.0
MC03	3000	80 - 320	10.5
MC05	5000	80 - 320	11.0
MC10	10000	90 - 320	16.0



# MAXIWINCH®

## WIRE ROPE WINCHES

A range of wire rope pulling machines with built-in safety features and long lasting durability for industrial applications. Pull, lift, lower and position with complete safety.



Maxiwinch wire rope winches are suitable for pulling, lifting, tensioning and releasing in any direction.

Maxiwinches are available in light and compact aluminium and pressed steel construction for applications where aluminium is not recommended.

Maxiwinch wire rope winches are available in different capacities as shown below, with rope lengths made to order.

- 1 Built-in shearing pin**  
Prevents overloading. It functions at approx. 25% overload and the pins can be replaced without removing the load.
- 2 Backward & Forward levers**  
Placed in tandem providing a slim design and assuring power transfer along the centre.
- 3 Spare shear pins**  
Two pieces of spare shear pins located in the carrying handle.
- 4 Rope clamp system**  
Easily disengaged with a lever allowing smooth installation of wire rope.



Aluminium Casing Maxiwinch



### SPECIFICATIONS & DIMENSIONS (ALUMINIUM CASING)

Model Number (ALUMINIUM CASING)	Capacity of Force (kg)	Rope Diameter (mm)	Net Weight (kg)	Overall Length (mm)	Overall Height (mm)	Overall Width (mm)
MWU08	800	8	6	426	235	64
MWU16	1600	11	11	545	280	97
MWU32	3200	16	22	660	325	116
MWU54	5400	20	59	930	480	152

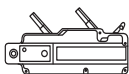

### SPECIFICATIONS & DIMENSIONS (STEEL CASING)

Model Number (STEEL CASING)	Capacity of Force (kg)	Rope Diameter (mm)	Net Weight (kg)	Overall Length (mm)	Overall Height (mm)	Overall Width (mm)
MWSTU08	800	8	8	440	265	63
MWSTU16	1600	11	14.5	550	300	77
MWSTU32	3200	16	28	690	350	91

### MAXIWINCH ROPE

Wire ropes with eye or swivel hooks on one end are available in any length required.

Wire ropes with copper ferrules are available for applications where aluminium is to be avoided.

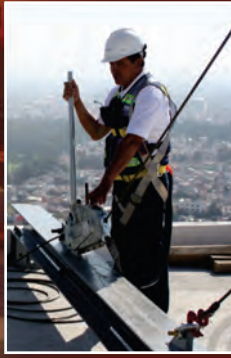

# MAXIWINCH®

## WIRE ROPE WINCHES

A range of wire rope pulling machines with built-in safety features and long lasting durability for industrial applications. Pull, lift, lower and position with complete safety.

### INCREASE THE PULLING & LIFTING CAPACITY

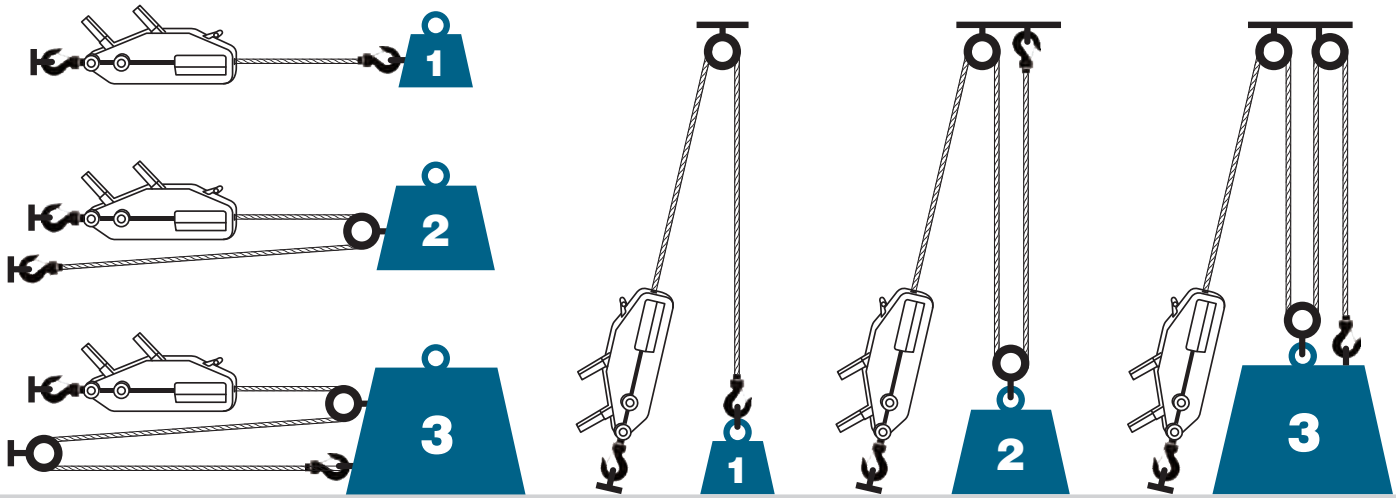

The pulling and lifting capacity of MAXIWINCH Wire Rope Winches can be increased greatly by use of sheave blocks in various configurations. These can increase the nominal capacity of the winch by 2, 3 or more times (see illustrations above).

Allowance must be made for friction in the sheaves. Always ensure that the capacity of the sheave blocks, anchor points and all fittings are suitable for the load.

### CHECK BEFORE EACH USE

- Inspect the MAXIWINCH for defects such as excessive wear, twisted or bent links
- Check the wire for bird caging or kinks and ensure that the free end is slightly tapered to enable easy threading through the winch
- Check hooks for distortion or damage
- Ensure that the branding label is in good condition and clearly legible
- Withdraw the winch from service if any of these defects are visible

### CAUTION!



Always follow the operating instructions as indicated on the branding label  
Always wear the correct safety gear when using wire rope winches

### LUBRICATION & CLEANING

- Lubricate all moving parts EXCEPT THE PULLING JAWS with engine oil
- Keep all visual parts clean and free from grease and oil
- Remove the wire rope after use and coil properly



Steel Casing Maxiwinch

# VITALIFT®

## LIFTING & TRANSPORT POINTS

Thiele lifting points serve to create a secure lifting or lashing point to enable safe handling and lashing activities.

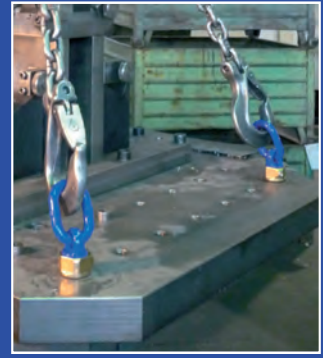

The **XS Screw Type Lifting Point XL TWN 1890 (EBLRTS)** can be rotated by 360° and swivelled by 180°. The extra wide bow enables easy slinging of bigger hooks. The XS-Lifting point is especially designed for the exchange of the bolts and therefore bolt length.

- Grade 100 with 4:1 Safety factor

**WARNING: DOES NOT SWIVEL UNDER LOAD!**

The **Grade 80 Weldable Lifting Point TWN 0119 (LETR)**

can be used for lifting and lashing. It is capable of its full working load limit in all directions and can pivot 180°. It can be welded easily and quickly to any steel construction thanks to its pre-aligned weld joint on the weld-on bracket.

- Grade 80 with 4:1 Safety factor

Inclination Angle  $\beta$

No. of Legs

**screwed type**

**EBLRTS - TWN 1890**  
XS-Lifting Point

**XL**  
by THIELE

		Working Load Limits in (t)										
		0.5	0.8	1.5	2.5	4	5	6	8	10	12	
		Marking	M10*	M12*	M16	M20	M24	M27*	M30	M36*	M42	M48*
		Thread Length**			30mm	38mm	41mm		58mm		78mm	
	0°	1			1.7	2.5	4.0		6.0		10.0	
	90°	1			1.7	2.5	4.0		6.0		10.0	
	0-45°	2			2.4	3.5	5.7		8.5		14.0	
	45-60°	2			1.7	2.5	4.0		6.0		10.0	
	0-45°	3+4			3.6	5.3	8.5		12.5		21.2	
	45-60°	3+4			2.6	3.8	6.0		9.0		15.0	

\* in development

\*\* longer threads available on request

**weldable**

**LETR - TWN 0119**  
Lifting Point

**GK8**

Working Load Limits in (t)							
1	2	3	5	8	15	32	
1.12	2	3.15	5.3	8	15	31.5	
1.12	2	3.15	5.3	8	15	31.5	
1.6	2.8	4.25	7.5	11.2	21.2	45	
1.12	2	3.15	5.3	8	15	31.5	
2.36	4.25	6.7	11.2	17	31.5	67	
1.7	3	4.75	8	11.8	22.4	47.5	



# THIELE®



Made in Germany

# VITALIFT®

## LIFTING POINTS

Thiele lifting points serve to create a secure lifting or lashing point to enable safe handling and lashing activities.



### The TITAN Screw Type Lifting point XL TWN 1120 (EBLR)

has a freely movable coupling link and is capable of lifting its full working load limit in all directions. It rotates easily due to the special bush and guide plate.

- Grade 100 with 4:1 Safety factor
- 100% Magnetic crack tested
- BG approved

**WARNING: DOES NOT SWIVEL UNDER LOAD!**

### The X-TREME Screw Type Lifting Point XL TWN 1830 (EBLRTB)

is equipped with a ball bearing system. It is well suited for loads that have to be turned or flipped. It has a special wide coupling link which enables easy slinging of bigger hooks. The X-TREME Lifting point is not suitable for permanent rotations under load.

- Grade 100 with 4:1 Safety factor
- 100% Magnetic crack tested
- BG approved

**SWIVELS UNDER LOAD**



	Marking	Working Load Limits in (t)																		
		0.3	0.45	0.6	1.4	2.5	3.5	6.7	8	0.45	0.6	1.4	2.5	3.5	5.3	8	10	12.5	15	
	Screw Size	M8	M10	M12	M16	M20	M24	M30	M36	M10	M12	M16	M20	M24	M30	M36	M42	M48	M56	
	Thread Length	19mm	19mm	24mm	29mm	33mm	40mm	52mm	66mm	15mm	18mm	20mm	25mm	30mm	40mm	50mm	60mm	68mm	78mm	
	0°	1	0.3	0.45	0.6	2.1	3	6	7.1	12.5	0.9	1.2	2.8	5.3	7	10	15	18	20	25
	90°	1	0.3	0.45	0.6	1.4	2.5	3.5	6.7	8	0.45	0.6	1.4	2.5	3.5	5.3	8	10	12.5	15
	0-45°	2	0.42	0.63	0.85	2	3.55	5	9	11.2	0.63	0.85	2	3.55	5	7.5	11.2	14	17.5	21.2
	45-60°	2	0.3	0.45	0.6	1.4	2.5	3.55	6.7	8	0.45	0.6	1.4	2.5	3.55	5.3	8	10	12.5	15
	0-45°	3+4	0.63	0.95	1.25	3	5.3	7.1	14	17	0.95	1.25	3	5.3	7.1	11.2	17	21.2	26.5	31.5
	45-60°	3+4	0.45	0.67	0.9	2.1	3.8	5.3	10	11.8	0.67	0.9	2.1	3.8	5.3	8	11.8	15	18.8	22.4



# THIELE®



Made in Germany

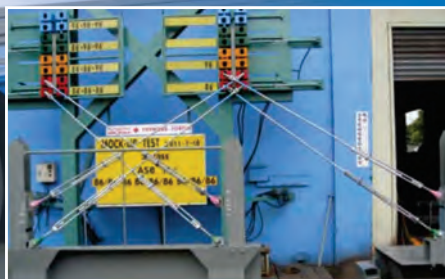

# DROP FORGED TURNBUCKLES

Generally to DIN 1480

### Available in:

- Eye-Eye (EE)
- Hook-Hook (HH)
- Eye-Hook (EH)
- Weldable ends (W)
- Material: Drop forged mild steel
- Standard: Generally to DIN 1480
- Finish: Electro-galvanized (Weldable ends: self coloured)

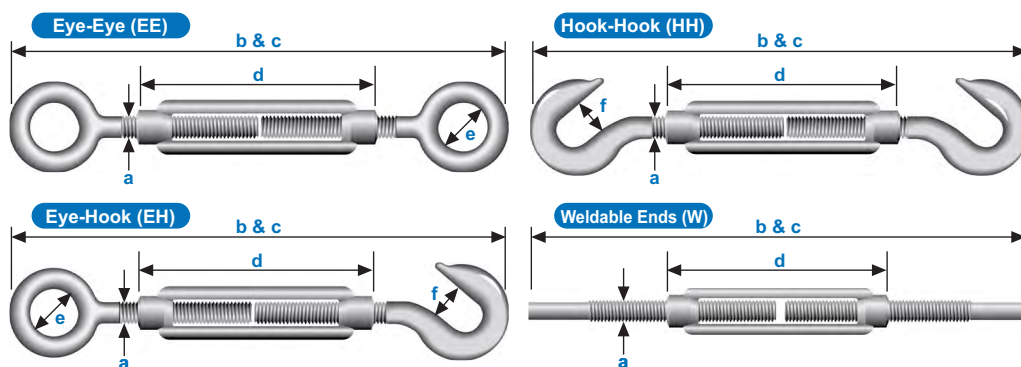

### SPECIFICATIONS

Diameter Thread a mm	Overall Closed Length				Overall Open Length				Body Length d mm	Eye Inside Diameter e mm	Hook Opening f mm	Max Tension tons
	EE b mm	HH b mm	EH b mm	W b mm	EE c mm	HH c mm	EH c mm	W c mm				
6	160	184	172	240	246	270	258	326	110	9	8.0	0.22
8	168	200	184	240	248	280	264	320	110	10	10.5	0.41
10	210	234	222	300	300	323	311	389	125	14	13.0	0.66
12	222	260	241	300	305	343	324	383	125	16	16.0	0.94
14	244	278	261	330	334	368	351	420	140	18	18.0	1.32
16	300	322	311	400	416	438	427	516	170	22	20.0	1.80
20	334	382	358	440	466	514	490	572	200	24	21.0	2.75
22	372	456	414	440	527	601	559	585	220	27	24.0	3.30
24	410	496	453	520	587	673	630	697	255	27	26.0	4.00
30	440	550	495	520	605	715	660	685	255	31	34.0	6.62
36	554	640	597	600	740	825	782	780	295	38	46.0	9.28

Maximum tension applies to eye and eye, others 33.3% of maximum tension.

# DIE CAST TURNBUCKLES

Commercial Quality

### Available in:

- Eye-Eye (EE)
- Eye-Hook (EH)
- Material: Body - Zinc Die Cast
- Hook and Eye - C15 (Bowed)
- Finish: Electro-galvanized

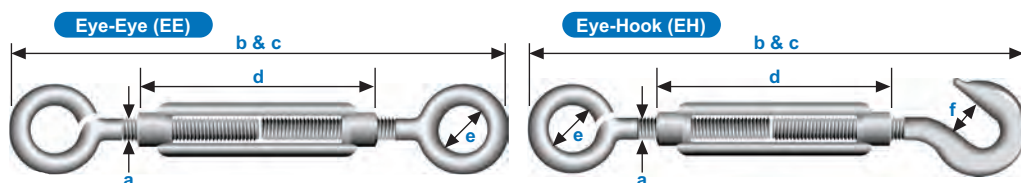

### SPECIFICATIONS

Diameter Thread a mm	Take up mm	Overall Closed Length		Overall Open Length		Body Length d mm	Eye Inside Diameter e mm	Hook Opening f mm
		EE b mm	EH b mm	EE c mm	EH c mm			
4	29	85	77	114	106	45	7	5
5	47	105	109	152	156	70	8	6

Also available: Stainless Steel Turnbuckles in 5, 6, 8, 10, 12, 16 and 20mm thread sizes.



# CLOSED BODY RIGGING SCREWS

With Drop-Forged End Fittings and Lock-Nuts

Available in:  
 Eye-Eye (EE)  
 Jaw-Jaw (JJ)  
 Eye-Jaw (EJ)  
 Material: Mild Steel  
 Safety Factor: MBL equals 5 X WLL  
 Finish: Hot dipped galvanized

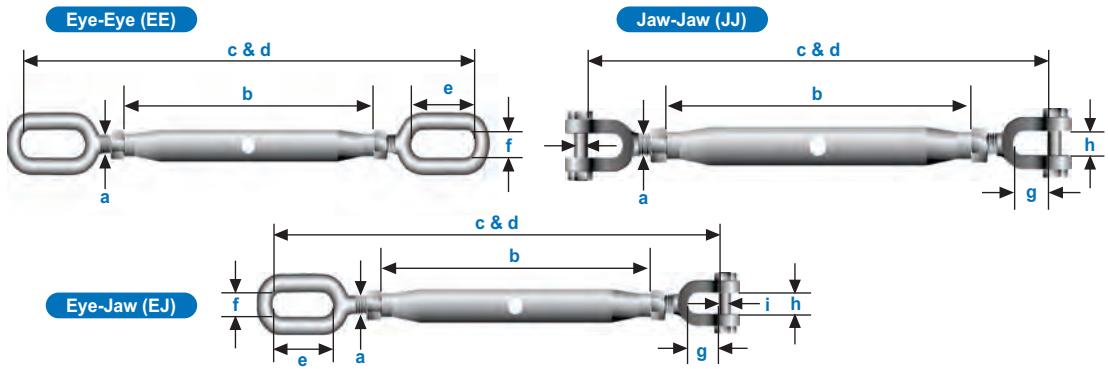

## SPECIFICATIONS

Working Load Limit Tons	Trade Size mm	Diameter Thread a mm	Body Length b mm	Closed Length			Open Length			Eye Inside Length e mm	Eye Inside Width f mm	Jaw Inside Length g mm	Jaw Inside Width h mm	Jaw Pin i mm
				EE c mm	JJ c mm	EJ c mm	EE d mm	JJ d mm	EJ d mm					
0.5	10	10	125	205	222	214	300	312	306	13	13	22	10.5	8
0.7	12	12	195	298	315	307	458	470	464	19	15	27	13	10
1.2	16	16	230	356	388	372	531	568	549	28	20	33	18	12
1.5	20	20	270	423	449	436	628	654	641	34	24	38	20	16
2.2	22	22	295	463	490	477	688	715	701	34	24	45	25	20
3.2	24	24	325	502	538	520	752	793	772	37	28	52	30	22
4.8	32	33	370	602	680	641	882	965	923	41	35	70	38	30
6.0	38	39	400	651	707	679	951	1002	976	45	40	70	45	33
* 8.0	45	45	400	721	761	741	879	1011	945	49	49	86	50	39
* 11.0	48	48	400	767	780	774	1032	1005	1018	52	52	97	58	45

\* Round Eye

# HEAVY DUTY TURNBUCKLES

Generally to ASTM F1145-92

Available in:  
 Eye-Eye (EE)  
 Jaw-Jaw (JJ)  
 Eye-Jaw (EJ)  
 Material: Drop Forged High Tensile Steel SAE 1035 or 1045  
 Safety Factor: MBL equals 5 X WLL  
 Standard: Generally to ASTM F1145-92 (formerly U.S. Federal Specification FF-T-791b)  
 Finish: Jaw Ends have Cotter Pins

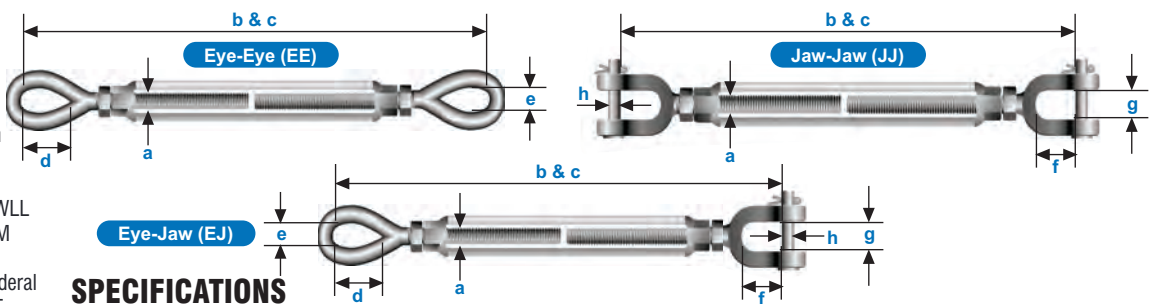

## SPECIFICATIONS

Working Load Limit Tons	Trade Size mm	Diameter Thread a inch	Take Up inch	Closed Length			Open Length			Eye Inside Length d mm	Eye Inside Width e mm	Jaw Inside Length f mm	Jaw Inside Width g mm	Jaw Pin h mm
				EE b mm	JJ b mm	EJ b mm	EE c mm	JJ c mm	EJ c mm					
9.7	38	1 1/2	12	756	675	716	1023	941	982	105	54	71	52	35
12.7	45	1 3/4	18	1019	933	980	1396	1310	1356	119	60	86	59	42
16.8	51	2	24	1264	1153	1208	1783	1672	1728	147	69	93	63	51
27.2	64	2 1/2	24	1429	1254	1341	1965	1830	1866	165	80	114	75	57

Also available: Long Body Turnbuckles to ASTM F1145-92 (formerly U.S. Federal Specification FF-T-791b) with 1/4, 5/16, 3/8, 1/2, 5/8, 3/4 and 1 inch threads.  
 Stainless Steel Closed Body Rigging Screws in 6, 8, 10, 12 and 16mm thread sizes.



# SHACKLES

Green Pin from Van Beest is a premium European manufactured shackle respected worldwide and has become synonymous with exceptional quality, safety and professional reliability.

## Green Pin® Standard Shackles

- **Material** : Bow and pin high tensile steel, Grade 6, quenched and tempered
- **Safety Factor** : MBL equals 6 x WLL
- **Standard** : EN 13889 and meets performance requirements of US Fed. Spec. RR-C-271  
DNV type approved to certification note 2.7-1
- **Finish** : Hot dipped galvanized
- **Temperature Range** : -20°C up to +200°C
- **Certification** : At no extra charges this product can be supplied with a works certificate, material certificate, manufacturer test certificate and/or EC Declaration of Conformity



**SANS 2415**  
Compliant



G-4161



G-4151

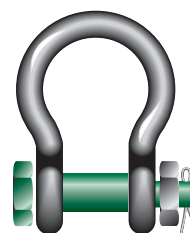
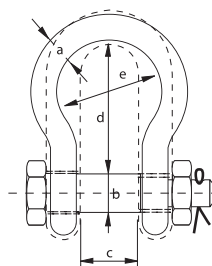

G-4163

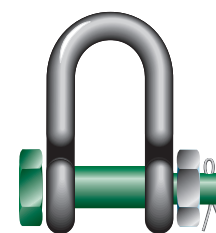

G-4153

working load limit	diameter bow	diameter pin	width inside	length inside		width bow	weight each	
				dee type	bow type		screw pin	safety bolt
tons	a mm	b mm	c mm	d mm	d mm	e mm	kg	kg
0.33	5	6	9.5	19	22	16	0.02	--
0.5	7	8	12	22	29	20	0.05	0.06
0.75	9	10	13.5	26	32	22	0.10	0.11
1	10	11	17	32	36.5	26	0.14	0.16
1.5	11	13	19	37	43	29	0.19	0.22
2	13.5	16	22	43	51	32	0.36	0.42
3.25	16	19	27	51	64	43	0.63	0.74
4.75	19	22	31	59	76	51	1.01	1.18
6.5	22	25	36	73	83	58	1.50	1.77
8.5	25	28	43	85	95	68	2.21	2.58
9.5	28	32	47	90	108	75	3.16	3.66
12	32	35	51	94	115	83	4.31	4.91
13.5	35	38	57	115	133	92	5.55	6.54
17	38	42	60	127	146	99	7.43	8.19
25	45	50	74	149	178	126	12.84	14.22
35	50	57	83	171	197	138	18.15	19.85
42.5	57	65	95	190	222	160	26.29	28.33
55	65	70	105	203	260	180	37.6	39.59
85	75	83	127	229	329	190	--	62





# SHACKLES & WIRE ROPE CLIPS

Green Pin from Van Beest is a premium European manufactured shackle respected worldwide and has become synonymous with exceptional quality, safety and professional reliability.

## Green Pin® Heavy Duty Shackles

- Material** : Bow and pin alloy steel, Grade 8, quenched and tempered
- Safety Factor** : MBL equals 5 x WLL
- Finish** : Shackle bow painted silver, pin painted green (120 tons shackle is hot dipped galvanized)
- Certification** : At no extra charges this product can be supplied with a works certificate, material certificate, manufacturer test certificate, EC Declaration of Conformity and all shackles starting from 150 tons are supplied with a Lloyd's Register of Shipping Certificate on proof load
- Note** : + 5% forging tolerance on inside width and length

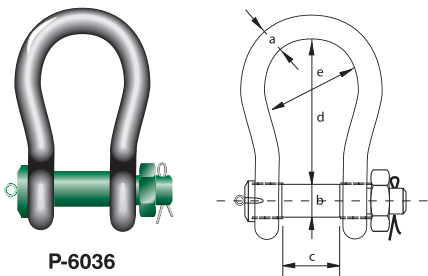

P-6036

working load limit	diameter bow	diameter pin	width inside	length inside	width bow	weight each
tons	a mm	b mm	c mm	d mm	e mm	kg
120	95	95	147	400	238	110
150	105	108	169	410	275	160
200	120	130	179	513	290	235
250	130	140	205	554	305	285
300	140	150	205	618	305	340
400	170	175	231	668	325	560
500	180	185	256	718	350	685
600	200	205	282	718	375	880
700	210	215	308	718	400	980
800	210	220	308	718	400	1100
900	220	230	328	718	420	1280
1000	240	240	349	718	420	1460
1250	260	270	369	768	450	1990
1500	280	290	369	818	450	2400

## Green Pin® wire rope clips generally to EN 13411-5 Type B

- Material** : Bridge : Drop forged high tensile steel SAE 1045  
U-bolt : SAE 1015
- Standard** : EN 13411-5 Type B  
Formerly U.S. Federal Specification FF-C-450D
- Finish** : Hot dipped galvanized nuts for diameter bow 5 and 6 mm are electro-galvanized
- Certification** : A works certificate can be supplied upon request

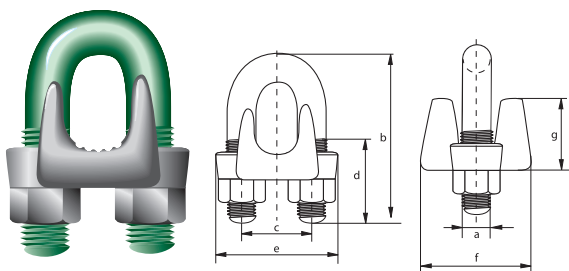

G-6240

diameter wire rope	diameter a	diameter b	length bow c	width inside d	length thread e	length base f	thickness base g	height base g	weight per 100 pcs
inch	mm	mm	mm	mm	mm	mm	mm	mm	kg
1/8	4	5	24	12	11	24	21	10	2
3/16	5	6	31	15	13	29	24	13	4
1/4	7	8	34	19	13	37	30	18	8
5/16	8	10	45	22	19	43	33	19	14
3/8	10	11	49	26	19	49	42	25	19
7/16	11	12	60	30	25	58	46	26	31
1/2	13	13	61	30	25	58	48	31	34
9/16	15	14	72	33	32	63	52	31	36
5/8	16	14	74	33	32	64	54	36	45
3/4	20	16	86	38	37	72	57	38	68
7/8	22	19	98	45	41	80	62	40	108
1	26	19	108	48	46	88	67	47	113
1 1/8	30	19	117	51	51	91	73	48	140
1 1/4	34	22	130	59	54	105	79	56	207
1 3/8	36	22	140	60	59	108	79	58	234
1 1/2	40	22	147	66	60	112	85	64	266
1 5/8	42	25	161	70	67	121	92	67	329
1 3/4	46	29	174	78	70	134	97	76	441
2	52	32	195	86	78	150	113	85	603
2 1/4	58	32	213	98	81	162	116	100	707
2 1/2	65	32	227	105	87	168	119	113	806
2 3/4	72	32	243	112	91	174	127	124	1000
3	78	38	271	121	98	194	135	136	1440



Holland



# ALLOY DEE & BOW SHACKLES

Lifting shackles generally to US Fed. Spec. RR-C-271

- Screw Pin and Safety (Bolt, Nut and Split Pin) Shackles
- Safety Factor: 5:1
- Material: Bow and pin high tensile steel, Grade 6
- Standard: Generally to US Fed. Spec. RR-C-271
- Finish: Hot dipped galvanized (Nuts on small sizes electro-galvanized)
- All measurements approximate and subject to tolerances

## SPECIFICATIONS

Dee & Bow SWL Short Tons	Dee & Bow Body Diameter mm	Dee & Bow Pin/Bolt Diameter mm	Dee & Bow Inside Width at Pin mm	Bow Only Inside Width at Bow mm	Dee Only Inside Length mm	Bow Only Inside Length mm	Dee Only Approx. Weight kg	Bow Only Approx. Weight kg
0.5	6	8	12	19	23	27	0.05	0.05
0.75	8	10	13	21	20	31	0.08	0.10
1	10	11	17	26	33	37	0.11	0.14
1.5	11	13	18	29	37	44	0.18	0.19
2	13	16	20	33	46	48	0.27	0.29
3.25	16	20	27	43	52	61	0.55	0.63
4.75	20	22	30	51	61	71	1.02	1.06
6.5	22	25	36	58	76	84	1.43	1.53
8.5	25	28	44	67	83	95	2.16	2.42
9.5	28	32	47	73	91	107	3.06	3.09
12	32	35	52	81	101	119	4.11	4.31
13.5	35	38	58	91	118	134	5.28	6.02
17	38	42	61	98	125	144	7.24	8.04
25	44	51	74	126	150	180	12	14
35	51	56	85	143	170	197	19	21
55	64	70	105	184	203	267	33	39
85	76	85	128	215	215	315	56	70
120	89	95	133	230	240	365	98	120
150	102	108	141	250	-	375	-	140

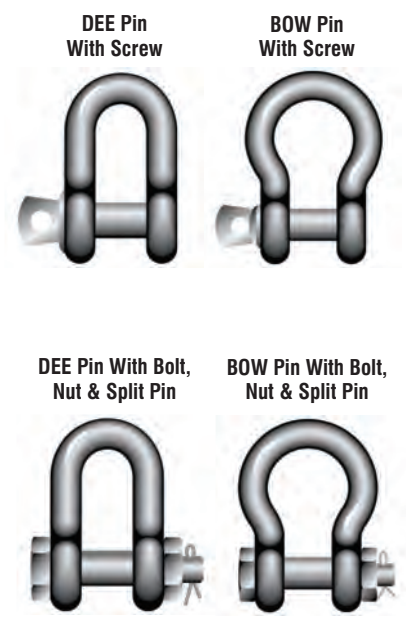

# LARGE DEE SHACKLES

Shackles generally to British Standard Specification B.S. 3032

- Material: Bow and pin alloy steel, EN14a
- Safety Factor: 4:1
- Standard: Generally to B.S. 3032
- Finish: Hot dipped galvanized, electro-galvanized or self colour
- All measurements approximate and subject to tolerances

## SPECIFICATIONS

SWL Metric Tons	Body Diameter mm	Pin Diameter mm	Inside Width mm	Inside Length mm	Approx. Weight kg
0.5	10	12	19	38	0.17
0.75	13	16	25	46	0.35
1.5	16	19	32	68	0.66
2	19	22	38	73	1.02
3	22	24	44	80	1.57
3.75	25	28	50	94	2.3
5	28	32	55	101	3.2
6	32	36	61	112	4.3
7	35	38	67	127	5.4
9.5	38	44	70	137	6.8
13	44	51	83	156	11.0
16.25	51	57	98	187	20.0
20	57	64	110	210	26.8

Large Dee Shackle



Due to our policy of continual product development, dimensions, weights and specifications may change without prior notice. Please check with your sales representative when ordering.



# HARDWARE CHAIN

- General purpose welded commercial chain
- Supplied in individual bags of 30M lengths
- Finish: Electro-galvanised or self-colour
- **Note: Not to be used for lifting applications**

*All measurements approximate and subject to commercial tolerances*  
*Stainless steel grade 316 chain also available, enquire for more details*

## SPECIFICATIONS

Item Code		Trade Size mm	Inside Link Length a mm	Inside Link Width b mm	Mass Per 30m kg
Self-Colour	Electro-galvanised				
CHH03B	CHH03G	3	19.5	5.3	4.98
CHH04B	CHH04G	4	24.0	7.2	8.01
CHH05B	CHH05G	5	25.0	8.6	12.18
CHH06B	CHH06G	6	25.8	10.5	17.76
CHH08B	CHH08G	8	32.0	14.2	37.83
CHH10B	CHH10G	10	35.0	15.0	55.71
CHH13B	CHH13G	13	50.0	19.6	96.72

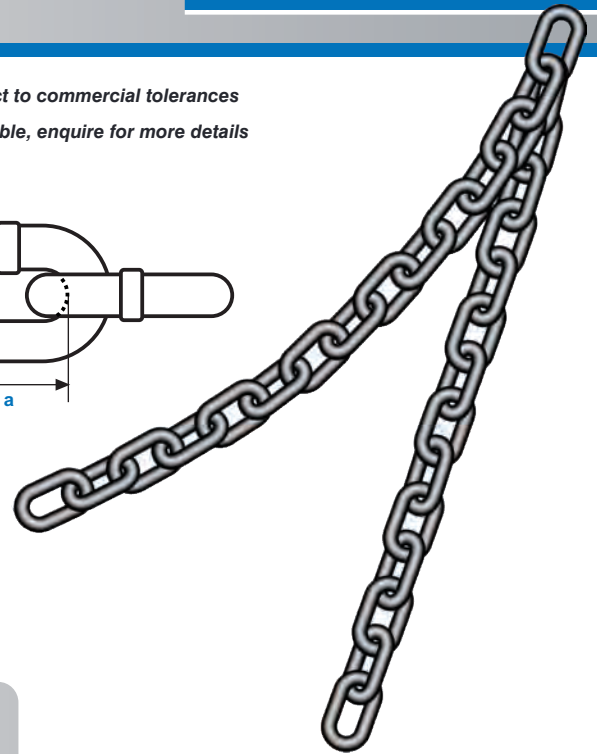
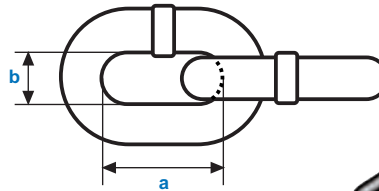

# COMMERCIAL SHACKLES

- Bow and Dee commercial shackles
- Material: Mild steel or stainless steel grade 316
- Finish: Electro-galvanised or stainless steel grade 316
- **Note: Not to be used for lifting applications**

*All measurements approximate and subject to commercial tolerances*

## SPECIFICATIONS

Item Code				Diameter Bow a mm	Diameter Pin b mm	Width Inside c mm	Length Inside d mm	Width Bow e mm
Electro-galvanised		Stainless Steel						
Dee	Bow	Dee	Bow					
SHC05D	SHC05B	SHS05D	SHS05B	5	5	10	20	15
SHC06D	SHC06B	SHS06D	SHS06B	6	6	12	24	18
SHC08D	SHC08B	SHS08D	SHS08B	8	8	16	32	24
SHC10D	SHC10B	SHS10D	SHS10B	10	10	20	40	30
SHC12D	SHC12B	SHS12D	SHS12B	12	12	24	48	36
SHC16D	SHC16B	SHS16D	SHS16B	16	16	32	64	48
SHC19D	SHC19B			19	19	38	76	57
		SHS20B	SHS20B	20	20	40	80	60
SHC22D	SHC22B	n/a	n/a	22	22	44	88	66
SHC24D	SHC24B	n/a	n/a	25	25	50	100	75
SHC28D	n/a	n/a	n/a	28	28	56	112	n/a
SHC32D	n/a	n/a	n/a	32	32	64	128	n/a
SHC38D	n/a	n/a	n/a	38	38	76	152	n/a
SHC50D	n/a	n/a	n/a	50	50	100	200	n/a

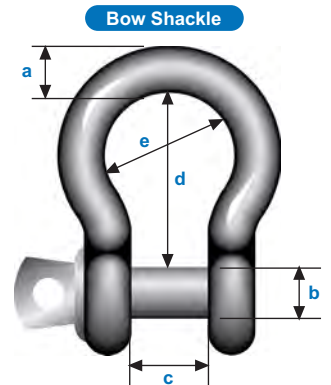
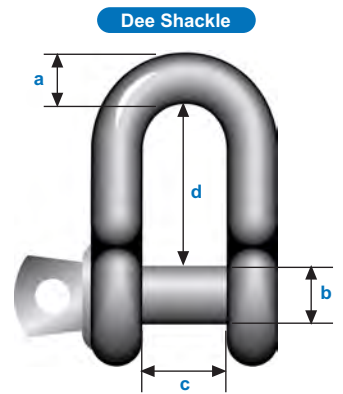

Due to our policy of continual product development, dimensions, weights and specifications may change without prior notice. Please check with your sales representative when ordering.



# QUICK LINKS

- Material: Mild steel or stainless steel grade 316
- Finish: Electro-galvanised or stainless steel grade 316
- **Note: Not to be used for lifting applications**

All measurements approximate and subject to commercial tolerances

## SPECIFICATIONS

Item Code		Diameter	Inside Width	Inside Length	Opening
Electro-galvanised	Stainless Steel	a mm	b mm	c mm	d mm
CHQL03	CHSSQL03	3.5	10	29	5
CHQL04	CHSSQL04	4	11	32	5
CHQL05	CHSSQL05	5	13	39	6
CHQL06	CHSSQL06	6	14	46	7
CHQL07	CHSSQL07	7	16	51	8
CHQL08	CHSSQL08	8	17	59	10
CHQL10	CHSSQL10	10	20	70	12
CHQL12	CHSSQL12	12	23	83	14
CHQL16	n/a	16	29	112	20

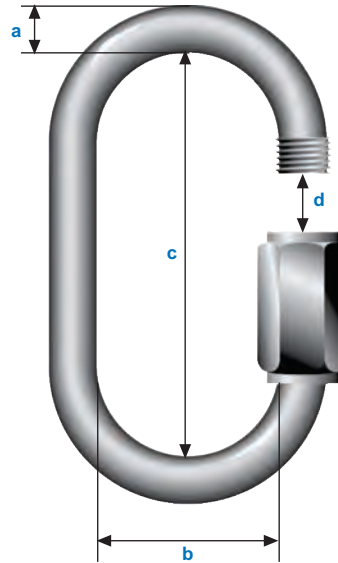

# CARABINE HOOKS

- Carabine hooks available: standard (plain), with pressed thimble (insert) or with a screw nut
- Material: Mild steel or stainless steel grade 316
- Finish: Electro-galvanised or stainless steel grade 316
- **Note: Not to be used for lifting applications**

All measurements approximate and subject to commercial tolerances

## SPECIFICATIONS

Item Code						Diameter a mm	Length b mm	Diameter Inside Thimble c mm	Width Inside d mm	Width Opening e mm
Electro-galvanised			Stainless Steel							
Std.	Insert	Screw Nut	Std.	Insert	Screw Nut					
HKCH04	HKCH04I	HKCH04SB	HKCHS04	HKCHS04I	HKCHS04SB	4	40	4	14	6
HKCH05	HKCH05I	HKCH05SB	HKCHS05	HKCHS05I	HKCHS05SB	5	50	5	16	6
HKCH06	HKCH06I	HKCH06SB	HKCHS06	HKCHS06I	HKCHS06SB	6	60	6	18	7
HKCH07	HKCH07I	HKCH07SB	n/a	n/a	n/a	7	70	7	22	8
HKCH08	HKCH08I	HKCH08SB	HKCHS08	HKCHS08I	HKCHS08SB	8	80	10	24	9
HKCH09	HKCH09I	HKCH09SB	n/a	n/a	n/a	9	90	12	26	10
HKCH10	HKCH10I	HKCH10SB	HKCHS10	HKCHS10I	HKCHS10SB	10	100	13	30	11
HKCH12	HKCH12I	HKCH12SB	HKCHS12	HKCHS12I	HKCHS12SB	12	140	15	40	19
HKCH14	HKCH14I	HKCH14SB	n/a	n/a	n/a	14	180	17	48	28

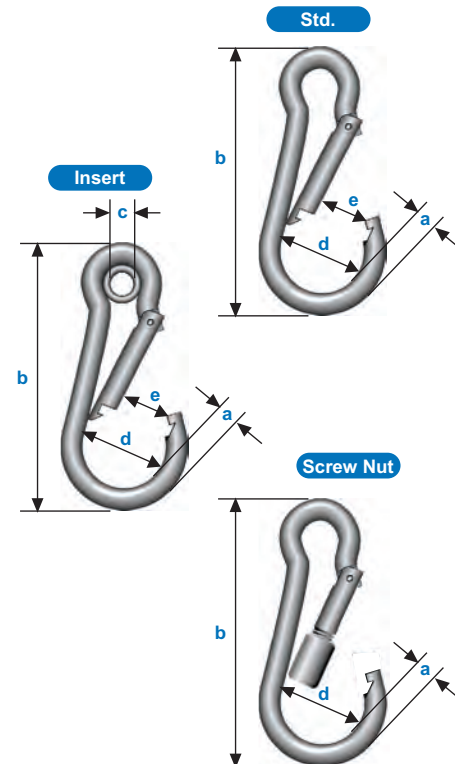

Due to our policy of continual product development, dimensions, weights and specifications may change without prior notice. Please check with your sales representative when ordering.



**Johan Kriel**

**E: [johan.kriel@drs-cd.com](mailto:johan.kriel@drs-cd.com)**

**M: +27 72 178 5406**

**Whatsapp: +27 72 178 5406**

**Suite 302, Zambia National Building Society, President Avenue, Ndola, Zambia**